



FM1010 User Manual

V1.1

Table of contents

1	INTRODUCTION	6
1.1	ATTENTION	6
1.2	INSTRUCTIONS OF SAFETY	6
1.3	LEGAL NOTICE	7
1.4	ABOUT DOCUMENT	7
2	BASIC DESCRIPTION	7
2.1	PACKAGE CONTENTS	7
2.2	BASIC CHARACTERISTICS	8
2.3	TECHNICAL FEATURES.....	9
2.4	ELECTRICAL CHARACTERISTICS.....	11
2.5	ABSOLUTE MAXIMUM RATINGS.....	11
3	CONNECTION, PINOUT.....	12
3.1	HOW TO INSERT SIM CARD INTO FM1010 DEVICE:	12
3.2	INSTALLING FM1010 DRIVERS	13
3.3	NAVIGATE LED.....	15
3.4	STATUS LED	15
3.5	OBD II	15
3.6	USB.....	16
4	FIRMWARE	17
4.1	UPDATING FIRMWARE USING USB CABLE	17
5	OPERATIONAL BASICS.....	18
5.1	OPERATIONAL PRINCIPALS.....	18
5.2	SLEEP MODES	18
•	<i>Sleep mode</i>	18
•	<i>Deep Sleep mode</i>	19
5.3	VIRTUAL ODOMETER.....	20
5.4	FEATURES.....	20
•	<i>Scenarios</i>	20
•	<i>Trip</i>	20
•	<i>Geofencing</i>	21
5.5	CONFIGURATION.....	21
5.6	INSTALLING FM1010 FOR CONFIGURATION:.....	21
5.7	CONFIGURATOR	22
5.8	RECORD STORAGE	24
5.9	SYSTEM SETTINGS.....	24
5.10	RECORDS SETTINGS.....	25
5.11	GSM SETTINGS, GPRS PART.....	26
5.12	GSM SETTINGS, SMS PART	26
5.13	IGNITION SOURCE SETTINGS	27
5.14	DATA ACQUISITION MODE SETTINGS	27
5.15	FEATURES SETTINGS.....	31
•	<i>Scenarios settings</i>	31
•	<i>Trip settings</i>	32
•	<i>Geofencing settings</i>	33
•	<i>SMS events</i>	35
5.14..1	SMS events configuration	37
5.16	I/O SETTINGS	40
•	<i>Event Generating</i>	42
•	<i>Hysteresis</i>	43
6	SMS COMMAND LIST	43

6.1	SMS COMMAND LIST.....	43
	• <i>getstatus</i>	44
	• <i>getweektime</i>	45
	• <i>getops</i>	45
	• <i>getcfgtime</i>	45
	• <i>ggps</i>	45
	• <i>getgps</i>	45
	• <i>getinfo</i>	46
	• <i>getver</i>	46
	• <i>allver</i>	47
	• <i>getio</i>	47
	• <i>radio #</i>	47
	• <i>getparam #####</i>	47
	• <i>setparam #####</i>	47
	• <i>flush #,#,#,#,#,#</i>	48
	• <i>banlist</i>	48
	• <i>crashlog</i>	48
7	DEBUG MODE	48
8	PARAMETER LIST	49
8.1	PARAMETERS VALUE TYPES.....	49
8.2	SYSTEM PARAMETERS	49
	• <i>Sleep Mode (ID=1000)</i>	49
	• <i>Sleep timeout (ID=1001)</i>	50
	• <i>Mode Switch Source (ID=1002)</i>	50
	• <i>Ignition Source (ID=1003)</i>	50
	• <i>Saving/Sending without time synchronization (ID=1005)</i>	50
	• <i>Power Voltage Low Level (ID=1006)</i>	50
	• <i>Power Voltage High Level (ID=1007)</i>	50
8.3	RECORDS PARAMETERS	51
	• <i>Sorting (ID=1010)</i>	51
	• <i>Active Data Link Timeout (ID=1011)</i>	51
	• <i>Server Response Timeout (ID=1012)</i>	51
8.4	GSM PARAMETERS	52
	• <i>GPRS content activation (ID=1240)</i>	52
	• <i>APN Name (ID=1242)</i>	52
	• <i>APN username (ID=1243)</i>	52
	• <i>APN Password (ID=1244)</i>	52
	• <i>Domain (ID=1245)</i>	52
	• <i>Target Server Port (ID=1246)</i>	53
	• <i>Protocol (ID=1247)</i>	53
	• <i>SMS Login (ID=1252)</i>	53
	• <i>SMS Password (ID=1253)</i>	53
	• <i>SMS data sending settings (ID=1250)</i>	53
	• <i>Authorized phone numbers (ID=1260-1269)</i>	53
	• <i>SMS Event PreDefined Numbers (ID=150-159)</i>	54
8.5	DATA ACQUISITION MODES PARAMETERS.....	54
	• <i>Home Network GSM operator code "Vehicle on STOP" parameters</i>	54
	8.5..1 Min Period (ID=1540)	54
	8.5..2 Min Saved Records (ID=1543).....	54
	8.5..3 Send Period (ID=1544).....	54
	8.5..4 GPRS Week Time (ID=1545).....	54
	• <i>Home Network GSM operator code "Vehicle MOVING" parameters</i>	55
	8.5..5 Min Period (ID=1550)	55
	8.5..6 Min Distance (ID=1551)	55
	8.5..7 Min Angle (ID=1552).....	55

8.5.8	Min Saved Records (ID=1553)	56
8.5.9	Send Period (ID=1554)	56
8.5.10	GPRS Week Time (ID=1555)	56
•	<i>Roaming Network GSM operator code “Vehicle on STOP” parameters</i>	56
8.5.11	Min Period (ID=1560)	56
8.5.12	Min Saved Records (ID=1563)	56
8.5.13	Send Period (ID=1564)	56
8.5.14	GPRS Week Time (ID=1565)	56
•	<i>Roaming Network GSM operator code “Vehicle MOVING” parameters</i>	57
8.5.15	Min Period (ID=1570)	57
8.5.16	Min Distance (ID=1571)	57
8.5.17	Min Angle (ID=1572)	57
8.5.18	Min Saved Records (ID=1573)	57
8.5.19	Send Period (ID=1574)	57
8.5.20	GPRS Week Time (ID=1575)	58
•	<i>Unknown Network GSM operator code “Vehicle on STOP” parameters</i>	58
8.5.21	Min Period (ID=1580)	58
8.5.22	Min Saved Records (ID=1583)	58
8.5.23	Send Period (ID=1584)	58
8.5.24	GPRS Week Time (ID=1585)	58
•	<i>Unknown Network GSM operator code “Vehicle MOVING” parameters</i>	58
8.5.25	Min Period (ID=1590)	58
8.5.26	Min Distance (ID=1591)	58
8.5.27	Min Angle (ID=1592)	59
8.5.28	Min Saved Records (ID=1593)	59
8.5.29	Send Period (ID=1594)	59
8.5.30	GPRS Week Time (ID=1595)	59
8.6	FEATURES PARAMETERS	59
•	<i>Scenarios Enable (ID=1600)</i>	59
•	<i>Max Acceleration Force (ID=1602)</i>	60
•	<i>Max Braking Force (ID=1603)</i>	60
•	<i>Max Angular Velocity (ID=1604)</i>	60
•	<i>Max allowed Speed (ID=1605)</i>	60
•	<i>Trip (ID=1280)</i>	60
•	<i>Start Speed (ID=1281)</i>	60
•	<i>Ignition Off Timeout (ID=1282)</i>	61
•	<i>Trip Continuous distance counting (ID=1283)</i>	61
•	<i>Geofencing</i>	61
8.6.1	Frame border (ID=1020)	61
8.6.2	Geofence Zone #1 Shape (ID=1030)	61
8.6.3	Geofence Zone #1 Priority (ID=1031)	61
8.6.4	Geofence Zone #1 Generate Event (ID=1032)	62
8.6.5	Geofence Zone #1 Longitude (X1) (ID=1033)	62
8.6.6	Geofence Zone #1 Latitude (Y1) (ID=1034)	62
8.6.7	Geofence Zone #1 Longitude (X2) (ID=1035)	62
8.6.8	Geofence Zone #1 Latitude (Y2) (ID=1036)	63
•	<i>AutoGeofencing</i>	63
8.6.9	Enable/Disable (ID=1101)	63
8.6.10	Activation Timeout (ID=1102)	63
8.6.11	AutoGeofence event Priority (ID=1103)	63
8.6.12	AutoGeofence event generating (ID=1104)	63
8.6.13	Radius (ID=1105)	64
8.7	ACCELEROMETER PARAMETERS	64
8.7.1	Acceleration range configuration (ID=1290)	64
8.7.2	Acceleration threshold configuration (ID=1291)	64
8.7.3	Acceleration duration (ID=1292)	64
8.7.4	Movement filter start (ID=1293)	64
8.7.5	Movement filter stop (ID=1294)	64
8.8	I/O PARAMETERS	65
•	<i>I/O#1 property parameter (ID=1300)</i>	65
•	<i>I/O#1 priority (ID=1301)</i>	65

- *I/O#1 High level (ID=1302)*..... 65
- *I/O#1 Low level (ID=1303)*..... 65
- *I/O#1 logic operand (ID=1304)*..... 66
- *I/O#1 averaging length (ID=1305)* 66
- 8.9 SMS EVENT CONFIGURATION 67
 - *I/O#1 element SMS event configuration (ID=100)* 67
- 9 MODULE INSTALLATION** **69**
 - 9.1 INSTALLING FM1010 MODULE: 69
 - 1) LOCATE OBD-II CONNECTOR IN YOUR CAR (SEE CAR OWNER’S MANUAL FOR THE LOCATION OF THE CONNECTOR) 69
 - 2) PLUG IN FM1010 DEVICE IN OBD-II CONNECTOR. 69
 - 3) IF STATUS AND NAVIGATE LED LIGHTS TURN ON, DEVICE IS READY TO USE..... 69
 - 9.2 INSTALLATION RECOMMENDATIONS:..... 69
- 10 CHANGE LOG** **70**

1 INTRODUCTION

1.1 Attention



Do not disassemble the device. If the device is damaged, before unplugging the power supply, do not touch the device.



All wireless data transferring devices produce interference that may affect other devices which are placed nearby.



Please consult representatives of your vehicle model regarding OBD II location on your vehicle. In case you are not sure of proper connection, please consult qualified personnel.



The programming must be performed using a second class PC (with autonomic power supply).



The device is susceptible to water and humidity.



Any installation and/or handling during a lightning storm are prohibited.



FM1010 has USB interface;
Please use cables provided with FM1010 device.
Teltonika is not responsible for any harm caused by using wrong cables for PC <-> FM1010 connection.



Warning! Do not use FM1010 device if it distracts driver or causes inconvenience due to OBD II placement. Device must not interfere with driver.

1.2 Instructions of safety

This chapter contains information on how to operate FM1010 safely. By following these requirements and recommendations, you will avoid dangerous situations. You must read these instructions carefully and follow them strictly before operating the device!

The device uses a 10 V...16 V DC power supply. The nominal voltage is 12 V DC. The allowed range of voltage is 10 V...16 V DC.

To avoid mechanical damage, it is advised to transport the FM1010 device in an impact-proof package.

Before dismounting the device from the vehicle, ignition must be off.

1.3 Legal Notice

Copyright © 2014 Teltonika. All rights reserved. Reproduction, transfer, distribution or storage of part or all of the contents in this document in any form without the prior written permission of Teltonika is prohibited.

Other products and company names mentioned here may be trademarks or trade names of their respective owners.

The manufacturer reserves the right to make changes and/or improvements at any time in design, functionality, parameters and electrical characteristics without any prior notice and without incurring obligations.

1.4 About document

This document contains information about the architecture, possibilities, mechanical characteristics, and configuration of the FM1010 device.

Acronyms and terms used in document

PC – Personal Computer.

GPRS – General Packet Radio Service

GPS – Global Positioning System

GNSS – Global Navigation Satellite System

GSM – Global System for Mobile Communications

SMS – Short Message Service

AC/DC – Alternating Current/Direct Current

I/O – Input/Output

Record – AVL data stored in FM1010 memory. AVL data contains GNSS and I/O information

AVL packet - data packet that is being sent to server during data transmission. AVL packet contains from 1 to 50 records.

2 BASIC DESCRIPTION

FM1010 is a terminal with GNSS and GSM connectivity, which is able to determine the object's coordinates and transfer them via the GSM network. This device is perfectly suitable for applications, which need location acquirement of remote objects. FM1010 has a USB port for device status log output and entering configurations.



Note: Monitorable basic vehicle parameters depend on vehicle mark and model.

2.1 Package contents¹

The FM1010 device is supplied to the customer in a cardboard box containing all the equipment that is necessary for operation. The package contains:

FM1010 device;

OBD II power supply adapter (accessory is optional);

USB cable.

170mAh Li-ion battery (optional)

¹ Package content depends on Order Code, and can be customized by customer needs.

2.2 Basic characteristics

GSM / GPRS features:

- Teltonika TM11Q quad band module (GSM 850 / 900 / 1800 / 1900 MHz);
- GPRS class 10;
- SMS (text, data).

GNSS features:

- TG3300 32 channel (or equivalent) receiver;
- Up to -161 dBm sensitivity.

Hardware features:

- Cortex®-M3 processor;
- 1 MB internal Flash memory
- Built-in accelerometer.

Interface features:

- Power supply: 10 ÷ 16V;
- USB port;
- Ignition input
- LEDs indicating device status.



Note: Ignition input parameter depends on vehicle mark and model.

Special features:

- Any element event triggers (speed, temperature, etc.);
- Highly configurable data acquisition and sending;
- Multiple Geo-fence areas;
- Sleep mode;
- Deep sleep mode;
- Configurable scenarios available;
- Authorized number list for remote access;
- Firmware update over GPRS or USB port;
- Configuration update over GPRS, SMS or USB port;
- TCP/IP or UDP/IP protocol support;
- Up to 8000 records storing.

2.3 Technical features

Part name	Physical specification
Navigation LED	LED
Modem LED	LED
GNSS	Internal GNSS antenna
GSM	Internal GSM antenna
OBD-II connector	Standard OBD-II connector
USB	Mini USB socket

Table 1. FM1010 specifications

Technical details
Power supply 10...16 V DC 2W Max Energy consumption ¹ : GPRS: --- average 85 mA r.m.s, Nominal: --- average 48 mA r.m.s, GNSS Sleep: --- average 21 mA, Battery charge current: --- average 100 mA, Deep Sleep: --- average less than 2 mA ² Operation temperature: -25°C ... +55°C Storage temperature: -40°C ... +70°C Storage relative humidity 5 ... 95 % (no condensation)

¹ Energy consumption has been tested at 12V voltage.

² When in Deep Sleep mode no data storing and sending is activated.

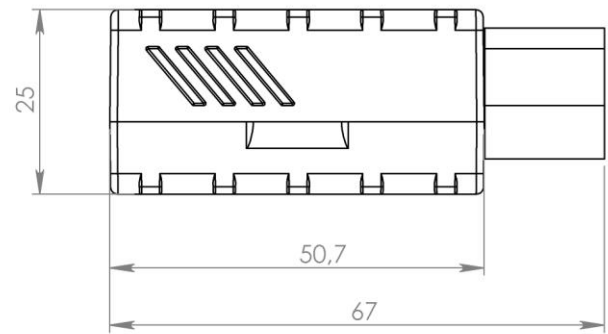
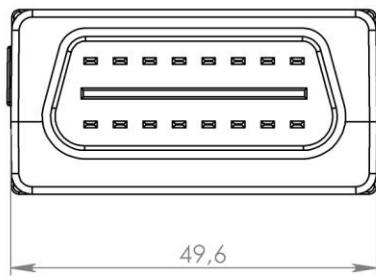
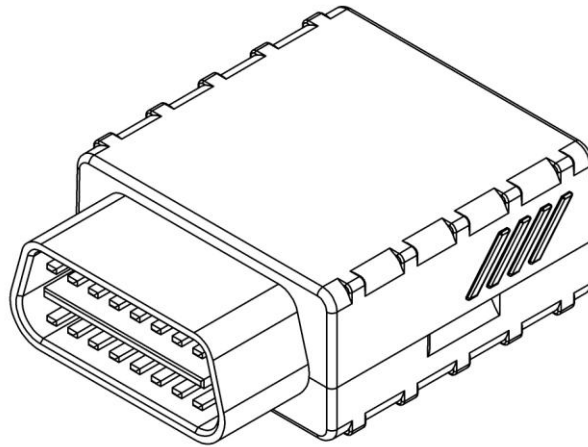

Figure 1 FM1010 view & dimensions (tolerance $\pm 1\text{mm}$)

2.4 Electrical characteristics

CHARACTERISTIC DESCRIPTION	VALUE	Min.	Typ.	Max.	Unit
Supply Voltage:					
Supply Voltage (Recommended Operating Conditions)		10		16	V
Digital Output (Open Drain grade):					
Drain current (Digital Output OFF)				120	uA
Drain current (Digital Output ON, Recommended Operating Conditions)				300	mA
Static Drain-Source resistance (Digital Output ON)				300	mOhm
Digital Input:					
Input resistance (Ignition)		15			kOhm
Input Voltage (Recommended Operating Conditions)		0		Supply voltage	V
Input Voltage threshold (Ignition)			5		V

2.5 Absolute Maximum Ratings

CHARACTERISTIC DESCRIPTION	VALUE	Min.	Typ.	Max.	Unit
Supply Voltage (Absolute Maximum Ratings)		-16		16	V
Digital Input (Ignition) Voltage (Absolute Maximum Ratings)		-32		32	V

3 CONNECTION, PINOUT

3.1 How to insert SIM card into FM1010 device:

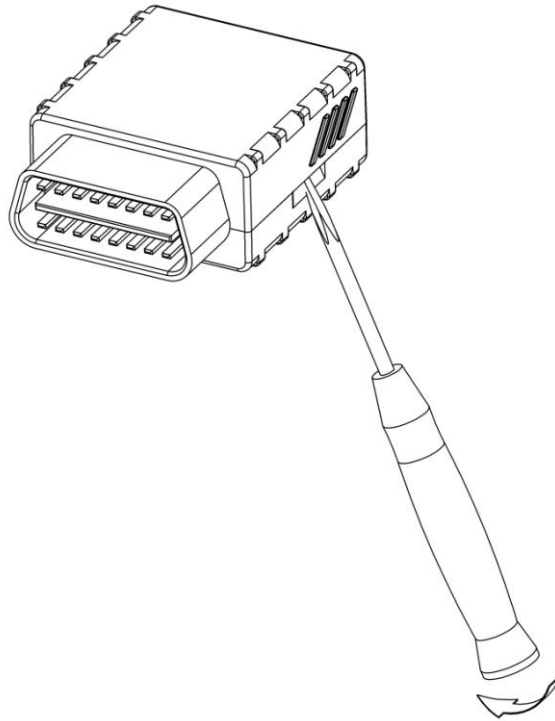

①

Gently open FM1010 case using screwdrivers

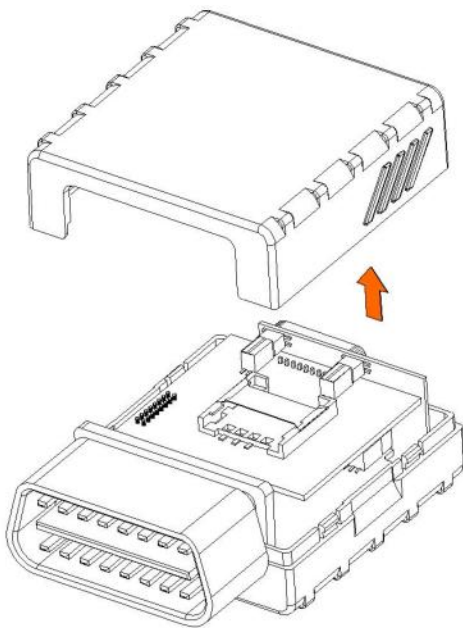

②

Remove FM1010 case

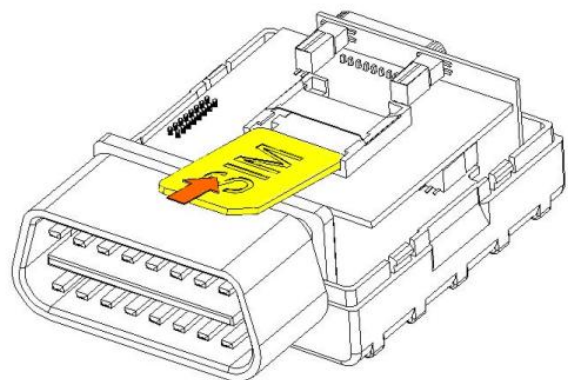

③

Insert SIM card as shown

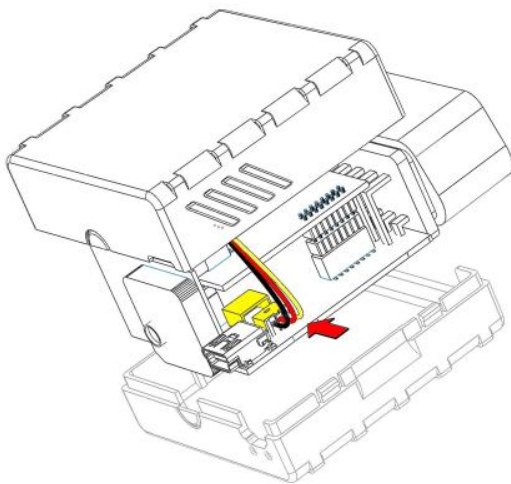

④

Insert battery wire to connector*

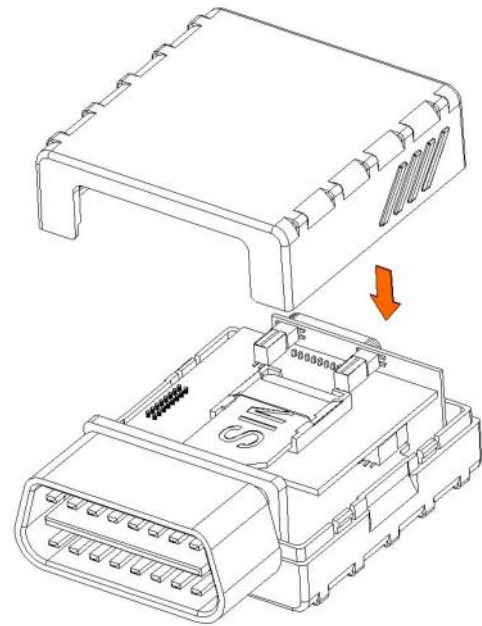

⑤

Attach top housing cover

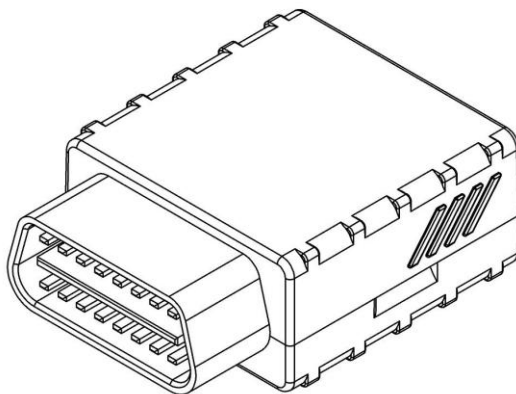

⑥

Device is ready

*Battery is optional

3.2 Installing FM1010 drivers

Software requirements:

- Operating system 32-bit and 64-bit: Windows XP with SP3 or later, Windows Vista, Windows 7.
- MS .NET Framework V3.5 or later (<http://www.microsoft.com> or <http://av11.teltonika.lt/downloads/tav/Framework/dotnetfx35setupSP1.zip>).

Drivers:

Please download Virtual COM Port drivers from Teltonika website:
http://av11.teltonika.lt/downloads/FM1010/vcpdriver_v1.3.1_setup.zip

Installing drivers:

Extract and run VCPDriver_V1.3.1_Setup.exe. This driver is used to detect FM1010 device connected to the computer. Click 'Next' in driver installation window (figures below):



Figure 2 Driver installation window

This will launch device driver installation wizard. In the following window click 'Next' button again:



Figure 3 Driver installation window

Setup will continue installing drivers and will display a window about successful process at the end. Click 'Finish' to complete setup:



Figure 4 Driver installation window

You have now installed drivers for FM1010 device successfully.

3.3 Navigate LED

Behaviour	Meaning
Permanently switched on	GNSS signal is not received
Blinking every second	Normal mode, GNSS is working
Off	GNSS is turned off because: <ul style="list-style-type: none"> • Deep sleep mode Or <ul style="list-style-type: none"> • GNSS antenna short circuited

3.4 Status LED

Behaviour	Meaning
Blinking every second	Normal mode
Blinking every 2 seconds	Deep sleep mode
Blinking fast for a short time	Modem activity
Blinking fast constantly	Boot mode
Off	<ul style="list-style-type: none"> • Device is not working Or <ul style="list-style-type: none"> • Device firmware being flashed

3.5 OBD II

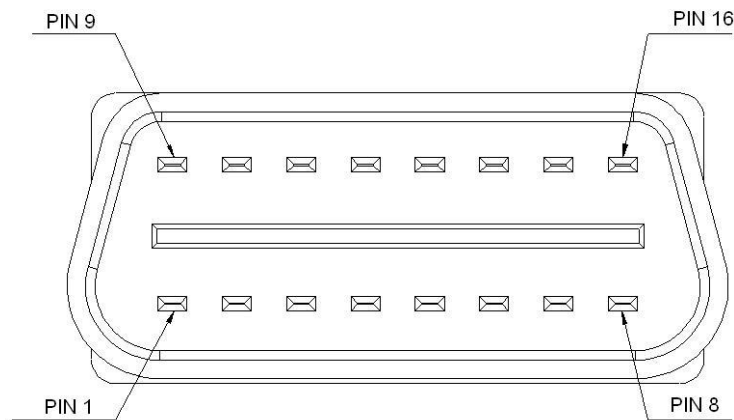

Figure 5 OBD II pinout

Pin Nr.	Pin Name	Description
1	Ignition input	
2	-	
3	-	
4	GND (-)	Ground pin.
5	GND (-)	Ground pin.
6	-	

7	-	
8	-	
9	-	
10	-	
11	-	
12	-	
13	-	
14	-	
15	-	
16	Power +(10÷16) V DC	Power range +(10...16) V DC to ground

Table 2. OBD II pinout description

3.6 USB

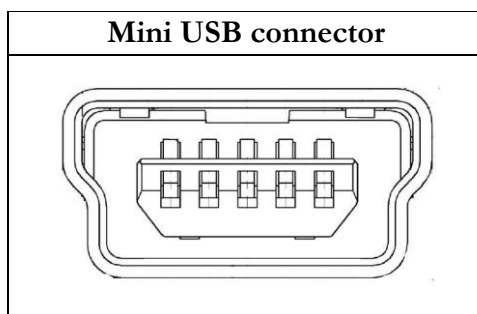

Figure 6 Mini USB type B connector

FM1010 connected to PC creates an STM Virtual COM Port, which can be used as a system port (to flash firmware and configure the device):

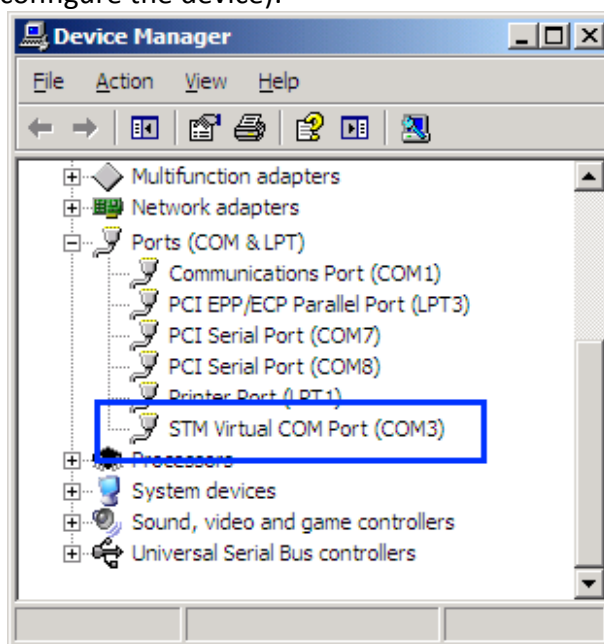

Figure 7 COM-Ports

4 FIRMWARE

4.1 Updating firmware using USB cable

FM1010 functionality is always improving, new firmware versions are developed. Current module firmware version can be retrieved from Configurator. See configuration description for details.

Contact sales manager to get the latest firmware.

Device must be powered on. Connect FM1010 to PC with the USB cable. Launch “Firmware Updater”, select COM port to which device is connected, click connect, and when IMEI and Firmware version fields are filled, start the update. Device needs some time to send IMEI and Firmware version, so do not be afraid if IMEI will not show up immediately, disconnect and after 1-2 minutes try to connect again. Update process may take up to several minutes.

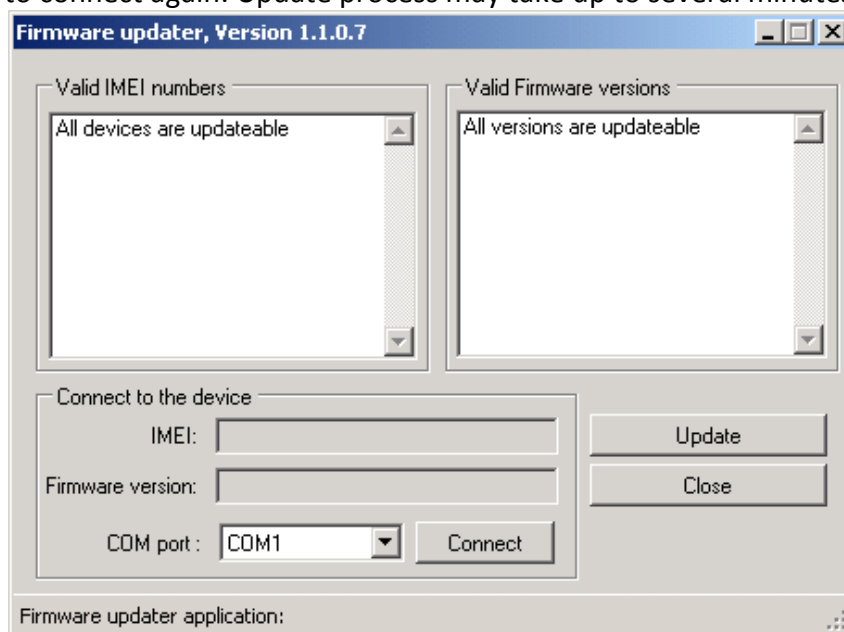

Figure 8 FM1010 firmware updater screen

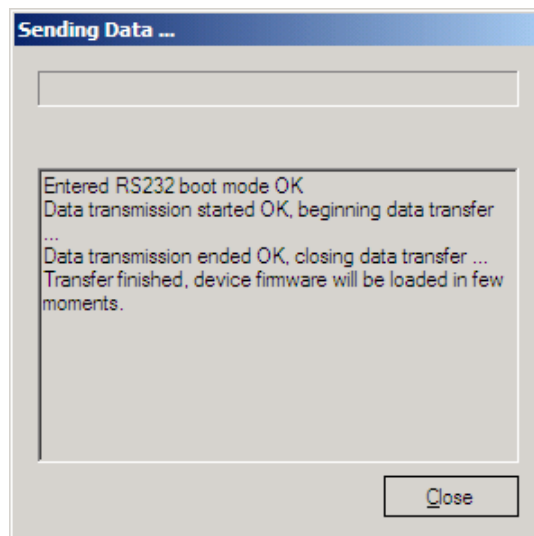

Figure 9 FM1010 firmware updating finished

When you see a table like in Figure 9, it means that the firmware is flashed to FM1010 successfully. You may now close the update window and start using your FM1010 device.

5 OPERATIONAL BASICS

5.1 Operational principals

FM1010 module is designed to acquire records and send them to the server. Records contain GNSS data and I/O information. Module uses GNSS receiver to acquire GNSS data and is powered with three data acquire methods: time-based, distance-based and angle-based method. Note, that if FM1010 loses connection to GNSS satellites, it continues to make records, however coordinate in these records remains the same (last known coordinate). Method's details are described in section 5.13. All data is stored in flash memory and later can be sent via GPRS.

GPRS and SMS settings are described in later sections. FM1010 communicates with server using special data protocol. Data protocol is described in "FMXXXX Protocols" document.

FM1010 can be managed by SMS commands. SMS Command list is described in SMS COMMAND LIST section. Module configuration can be performed over TCP or via SMS. Configuration parameters and modes are described in "FMXXXX Protocols" document.

5.2 Sleep modes

- Sleep mode

FM1010 is able to go to Sleep mode after configurable Sleep timeout. This timeout (defined period) starts counting when device is in STOP mode. After timeout is reached and all conditions for sleep mode are met, device goes to sleep mode. While in sleep mode, FM1010 turns GNSS module off and it is not making new periodic records. Only event records is being recorded with last known coordinate and sent to AVL server. As a result power usage decreases allowing saving vehicle battery.

FM1010 can enter sleep mode if **ALL** of these conditions are met:

- FM1010 has to be configured to work in Sleep mode;
- Device must be synchronized time with GNSS satellites;
- FM1010 has to be in „X on Stop Mode“ (Configured by Mode switch parameter);
- Ignition (Configured to be detected by Power Voltage, Ignition or Accelerometer) is off;
- Sleep timeout is reached.

FM1010 exits sleep mode when if **ONE** of following conditions are true:

- FM1010 switches to “X on Moving Mode”;
- Ignition (Configured to be detected by Power Voltage, Ignition or Accelerometer) is turned on.

- **Deep Sleep mode**

While in deep sleep mode, FM1010 sets GNSS receiver to sleep mode and turns off GSM/GPRS module (it is not possible to wake up device via SMS). Despite records with last known coordinate are being saved and send to AVL server (GSM/GPRS module is turned on to send data and after that it is turned off again), power usage is decreased to save vehicle's battery. Note, that power saving depends on two configurable parameters: send period and min. record saving period in “X on Stop Mode”.

FM1010 can enter deep sleep mode if **ALL** of these conditions are met:

- FM1010 has to be configured to work in Deep Sleep mode;
- Device must be synchronized time with GNSS satellites;
- FM1010 has to be in „X on Stop Mode“ (Configured by Mode switch parameter);
- Movement by accelerometer is not detected;
- Ignition (Configured to be detected by Power Voltage, Ignition or Accelerometer) is off;
- Min. Record Saving Period (Data Acquisition Mode settings) must be bigger than Active Data Link Timeout parameter, that FM1010 could close GPRS link.
- Send period (Data Acquisition Mode settings) minus Active Data Link Timeout must be more than 90 sec., that FM1010 could close GPRS link for at least 90 sec.
- USB cable is not connected.
- Sleep timeout is reached.

FM1010 exits deep sleep mode when if **ONE** of following conditions are true:

- Movement by accelerometer is detected;
- Ignition (Configured to be detected by Power Voltage, Ignition or Accelerometer) is turned on.
- USB cable is connected;



Note: In order to save GPRS traffic records saved in deep sleep mode do not contain below listed I/O elements information:
PDOP, HDOP, Odometer, Speedometer , Cell ID, Area Code, GNSS power

5.3 Virtual odometer

Virtual odometer is used to calculate traveled distance in FM1010 as a separate I/O element. When FM1010 detects movement, it starts counting distance using GNSS signal: every second it checks current location and calculates distance between current and previous point. It keeps adding these intervals until it is time to make a record, then FM1010 records its location and adds odometer value, which is equal to the sum of all distances, measured every second. When record is made, odometer resets to zero and distance calculation starts all over again.

Virtual odometer as an I/O element can be also used with Trip feature, read chapters [?] and [?] for more details.

5.4 Features

Using available features can greatly increase FM1010 usability options.

- **Scenarios**

Two scenarios are available on FM1010 device.

Green Driving **or/and** Over Speeding;

Green Driving Scenario. Helps to prevent and inspect driver about harsh driving. Scenario continuously monitors: accelerating force, braking force and cornering angles.

To save GPRS traffic Green Driving **event** will be **generated (included into sent records) only** when FM1010 measured values are higher than those set in configuration, without additional I/O settings.

To prevent generating false events, harsh acceleration and harsh braking is monitored only when following conditions are fulfilled:

- Ignition (Configured to be detected by Power Voltage, Ignition or Accelerometer) is turned on.
- Vehicle speed is equal or higher than 10km/h.

Harsh cornering is monitored only when following conditions are fulfilled:

- Ignition (Configured to be detected by Power Voltage, Ignition or Accelerometer) is turned on.
- Vehicle speed is equal or higher than 30km/h.



Note: Green Driving Scenario is a factor on various cars and various drivers testing phase and can be subject to changes. Teltonika is constantly working on improvement of the functionality of the devices, and strongly recommends using the latest version of the firmware.

Over Speeding Scenario. Helps to prevent from exceeding fixed speed and inspects driver if needed.

- **Trip**

Trip customizable feature enables user extended monitoring of performed trips (from engine start at present location to engine stop at arrived location), log their start and stop points,

view driven total distance³. Event will be **generated (included into send records) only** when trip starts and finishes.



Note: Scenarios and Trip features are activated only if Ignition (Configured to be detected by Power Voltage, Ignition or Accelerometer) is turned on.

- **Geofencing**

Geofencing is another feature which is highly customizable and can detect wherever car enters or leaves customized areas. More about Geofencing can be read in 5.15 Geofencing settings chapter.

Auto Geofencing feature if enabled is activated automatically by turning off car ignition (Configured to be detected by Power Voltage, Ignition or Accelerometer). Next time before driving user has to disable Auto Geofencing by turning on car ignition (Configured to be detected by Power Voltage, Ignition or Accelerometer). In case of theft car leaves Auto Geofencing zone without authorization FM1010 device automatically sends high priority record to AVL application.

5.5 CONFIGURATION

Installing FM1010 for configuration:

- Plug in device to OBD-II power adapter (accessory is optional).
- Connect output wires to DC power source (10-16V).
- Plug in USB mini cable.
- Open configurator and configure your device.

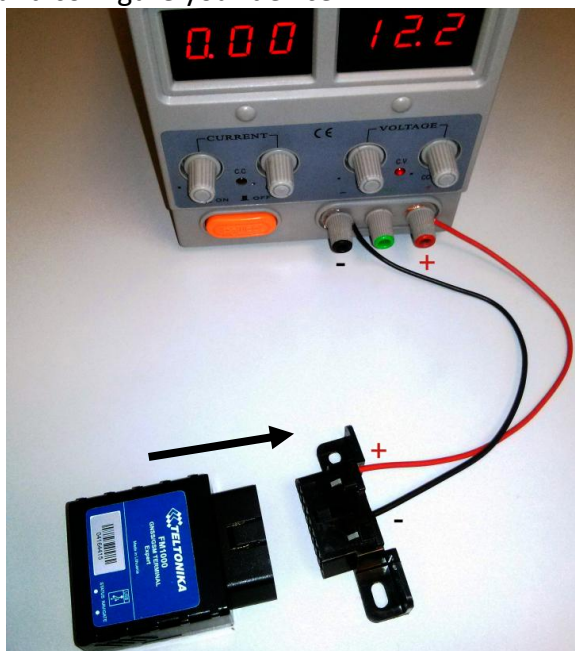

Figure 10 inserting FM1010 to OBD-II connector

³ Continuous odometer – total driven distance, works only in TRIP mode. Continues distance is counted only for ONE trip. If trip is finished (stop point is detected), odometer resets to 0 (zero). Next trip will start counting from the beginning.

5.6 Configurator

FM1010 configuration is performed via FM1010 Configurator program. FM1010 Configurator version can be downloaded from <http://av1.teltonika.it/downloads/FM1010/>. Contact sales manager to get the latest FM1010 Configurator version. FM1010 configurator operates on Microsoft Windows OS and uses MS .Net Framework 3.5 or higher. Please ensure that MS .Net Framework 3.5 or later is installed on your PC before starting configurator. Latest MS .Net Framework version can be downloaded from official Microsoft web page.

Module configuration is performed over USB cable. Configuration process starts from starting FM1010 Configurator program and then connecting to FM1010 device via Connect button located on the top left corner of configurator. If connected successfully IMEI, Version fields which were empty, now are filled with certain numbers depending on Modem IMEI and firmware version of your device (figure below).

New FM1010 module has default recommended factory settings. Recommended settings have optimal parameters to ensure best performance of track quality and online data sending.

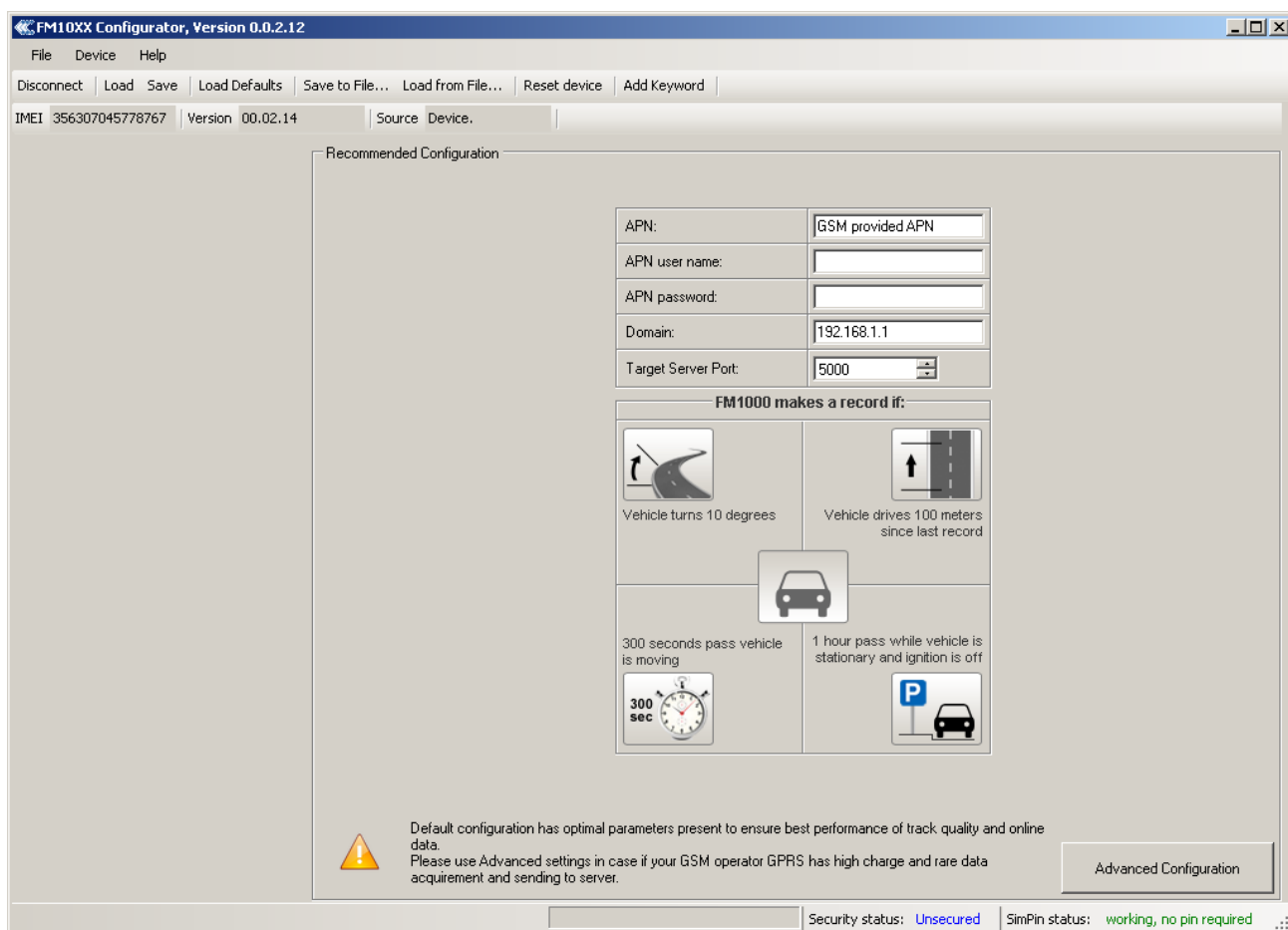
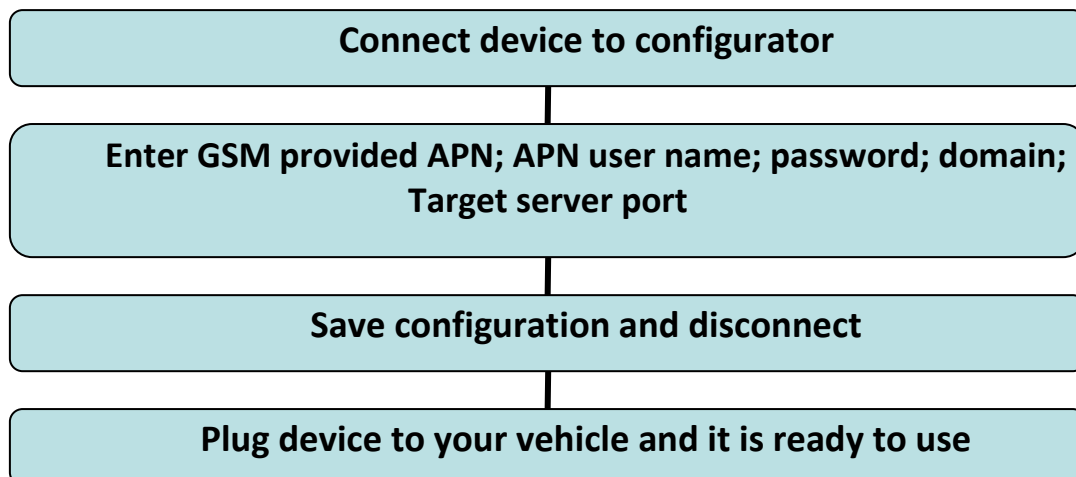

Figure 11 Configurator recommended configuration window

Recommended device configuration is simple and is performed as follows:



If you are not satisfied with recommended default device configuration or want to use additional FM1010 features such as geofencing, green driving etc. (all features are written below) use advanced device configuration. Just click Advanced configuration button on lower right corner in configurator and new menu options appears (figure 12). You can always go back to recommended configuration menu only by clicking Recommended Configuration button in main button area (area 1). For further device configuration in Advanced mode read description below.

FM1010 in advanced configuration has one user editable profile, which can be loaded from device, and saved. User can also revert to default settings, by pressing Load Defaults button. After any modification of configuration settings it has to be saved to FM1010 device, otherwise it will not be written to device.

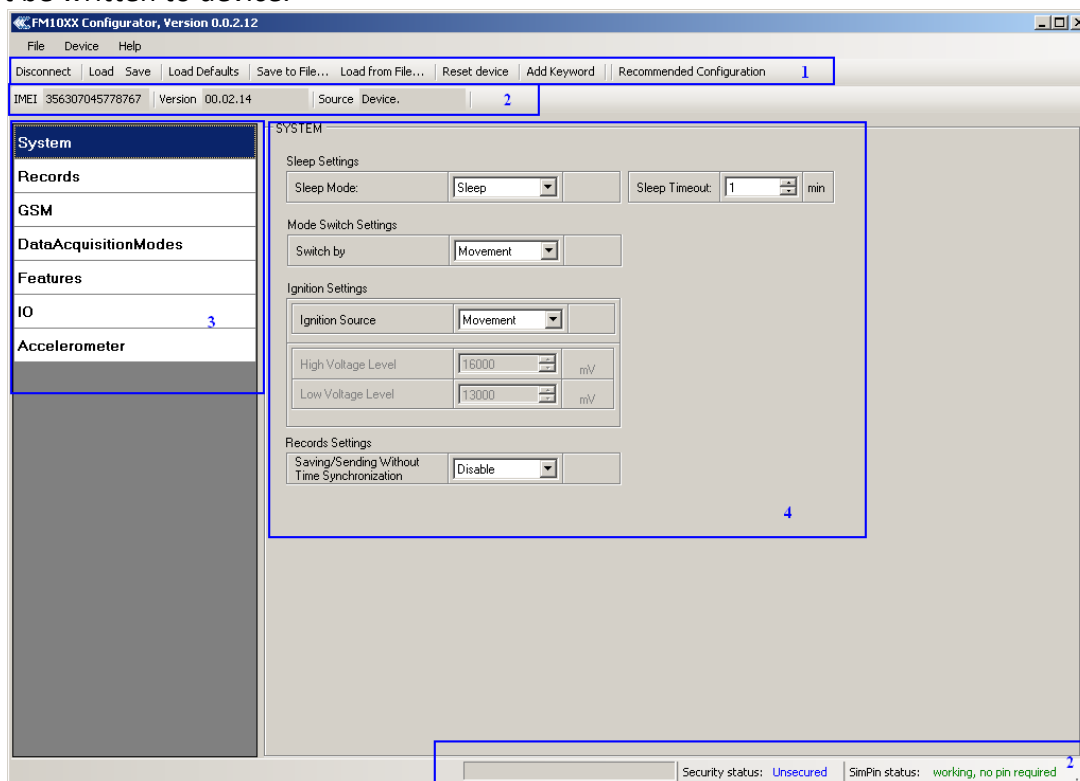

Figure 12 Configurator window

FM1010 Configurator is divided into 4 main areas: 1 – main button area, 2 – information area, 3 – settings menu, 4 – parameters and values menu.

Main Buttons description:

'Connect' – connects device

'Load' – reads configuration parameters from FM1010 Flash memory.

'Save' – saves configuration parameters to FM1010 Flash memory.

'Load Defaults' – loads default FM1010 settings that later can be modified. This procedure must be performed before entering new parameters.

'Save to File...' – allows user to save currently entered settings to .XML file, for later usage.

'Load from File...' – allows user to load configuration saved in .XML extension file.

'Reset device' – reboots FM1010 and displays processor firmware version.

Additional Buttons description:

'SIM PIN' - allows to enter PIN code if inserted SIM card has activated PIN code security. Note that PIN code can be entered 2 times. After that SIM CARD must be removed from FM1010 and PIN code entered manually.

'Add Keyword' / 'Change Keyword' / 'Switch Security Off' – buttons are used to protect configurator from unauthorized access to configuration.

Keyword is 4 – 10 symbol length. If keyword is set, every time user reconnects FM1010 to USB port, user will be asked to provide valid keyword when connecting FM1010 to configurator. User is given 5 attempts to enter keyword. After entering valid keyword, counter resets to 5.

If user disconnects FM1010 using 'Disconnect' button and does not disconnect from USB port, after reconnecting using 'Connect' button, configurator does not ask for keyword.



ATTENTION! If you have entered a keyword, disconnected from the configurator and then later connected again, you will need to enter the keyword that you have entered previously. If you have forgotten it, please contact your local sales manager.

5.7 Record storage

FM1010 can store up to 8000 data records if GSM or GPRS is not available at the moment. It will send data later when GPRS is available again. Note that FM1010 can have memory full of records. In such case it will start deleting oldest records in order to save new ones. Sending all the data records to server may take some time. Sending 8000 records for FM1010 may take for about 2 hours (exact time may differ depending on GPRS/server load).

You can access all uploaded data from TAVL4 application.

More details on how to use TAVL application please refer to "TAVL4 application user manual" documentation.

5.8 System settings

System settings have 4 configurable parameters:

- Sleep settings, where user can turn sleep/deep sleep on or off;
- Mode Switch Settings, where user can configure 3 ways how FM1010 will change its working mode (for working modes, read section 5.134)

- Ignition Settings, where user can configure ignition detection source (for ignition source, read section 5.133).
- Records Settings, where user can turn on saving/sending without time synchronization.

Mode Switch by	Vehicle on Stop mode	Vehicle Moving mode
Ignition (recommended)	If ignition is low (Configured to be detected by Power Voltage, Ignition or Accelerometer)	If ignition is high (Configured to be detected by Power Voltage, Ignition or Accelerometer)
Movement (accelerometer)	Internal accelerometer does not detect movement	Internal accelerometer detects movement
GNSS	GNSS fix is available and vehicle speed is lower than 5 km/h	GNSS fix is available and vehicle speed is higher than 5 km/h
	While GNSS fix is unavailable, Object Motion Detection Settings are working like in Movement mode	

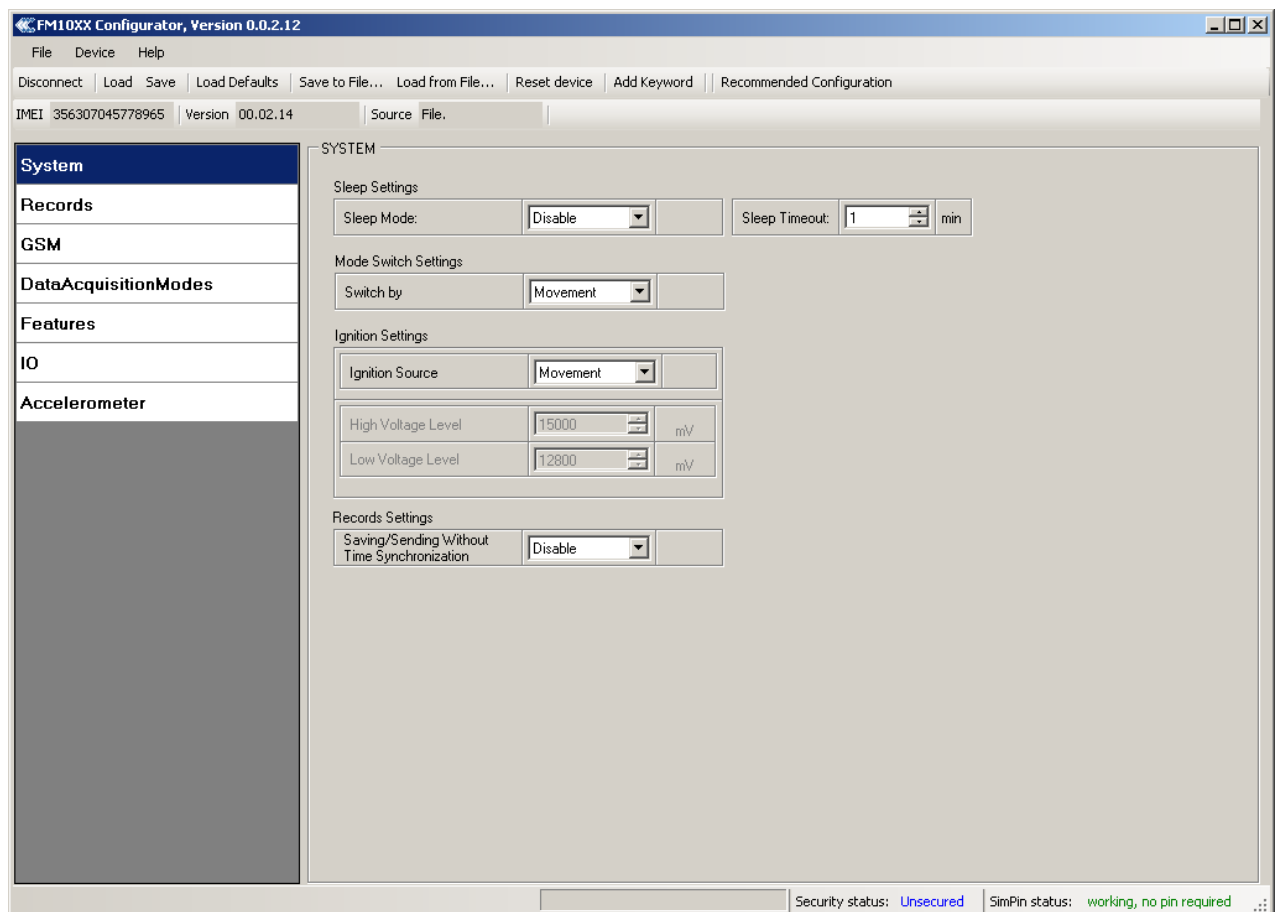

Figure 13 System settings configuration

5.9 Records settings

Here user can modify if FM1010 device will send newest records first, meaning, that the most important thing is to know recent position of car, older records are being sent right after newest records arrive to AVL application.

Activate Data Link Timeout is used to set timeout of link between FM1010 and AVL application termination. If FM1010 has already sent all records it waits for new records before closing link. If new records are generated in the period of this timeout, and minimum count to send is reached, they are sent to AVL application. This option is useful when GSM operator charge for link activation.

Server Response Timeout is used to set time period waiting for response from server side.

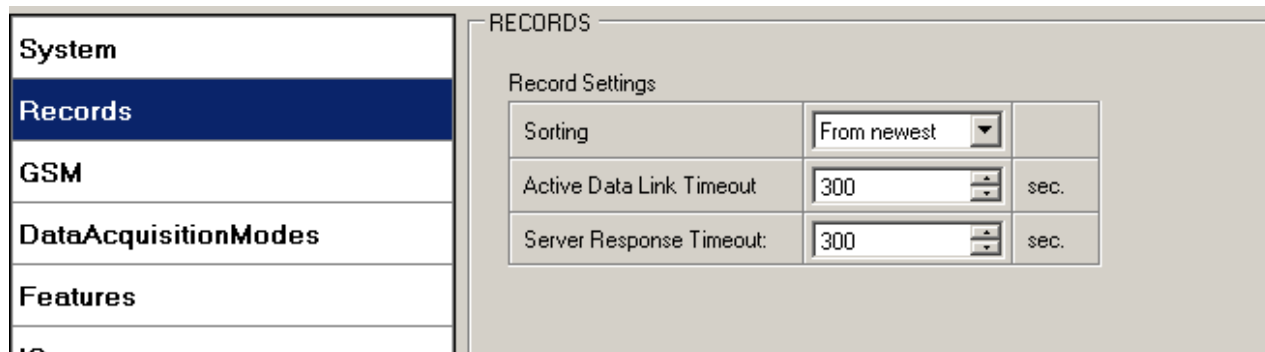

Figure 14 Records settings configuration

5.10 GSM settings, GPRS part

‘GPRS’ defines main parameters for FM1010 : GSM operator APN and GPRS username and password (optional – depending on operator), destination server IP and port, and allows to set protocol used for data transfers – TCP or UDP

Some operators use specific authentication for GPRS session – CHAP or PAP. If any of these is used, APN should be entered as ‘chap:<APN>’ or ‘pap:<APN>’. I.e. if operator is using APN ‘internet’ with CHAP authentication, it should be entered as ‘chap:internet’. Information about APN and authentication type should be provided by your GSM operator.

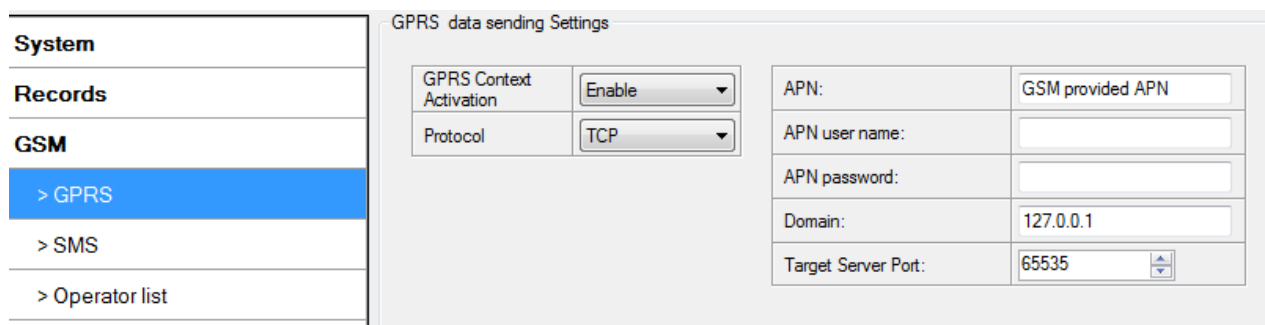

Figure 15 GPRS configuration

5.11 GSM settings, SMS part

Essential fields in ‘SMS’ are ‘SMS Login’ and ‘SMS Password’. The login and password are used with every SMS sent to FM1010 . If login and password are not set, in every SMS sent to FM1010 device two spaces before command have to be used (<space><space><command>).

Command structure with set login and password:

<login><space><password><space><command>, example: “asd 123 getgps”

Phone numbers have to be written in international standard, without using “+” or “00” signs in prefix. If no numbers are entered, configuration and sending commands over SMS are allowed from all GSM numbers.

SMS data sending settings – enable or disable **panic** event SMS usage. This setting does not affect replies to SMS request messages – answers are always sent back to sender telephone number.

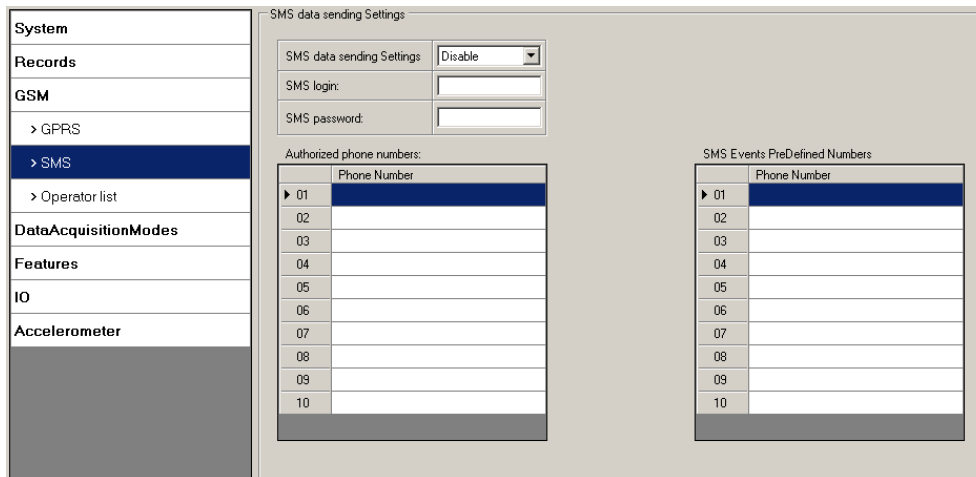

Figure 66 SMS configuration



Note: A mobile phone will not understand and SMS with binary code, so sending it to a mobile phone is useless. When sending a binary SMS to a phone number, which is a server phone number, the server can interpret and understand binary code, so the data can be read and you can view it on the server.



SMS login and password and authorized number list are used to protect FM1010 module from unauthorized access. Module accepts messages only from a list of authorized numbers and with proper module login and password. Numbers must be without “+” or “00” prefix. If no authorized numbers are entered, module accepts messages from all numbers.

5.12 Ignition Source settings

Ignition Source can be selected as Power Voltage, Digital Input 1 or Movement. This parameter has influence on all FM1010 application.

If ignition source is set to Power Voltage ranges for ignition detection must be configured. Ignition is set to 1 when Power Voltage is in range between Low & High Power Voltage Levels.

5.13 Data Acquisition Mode settings

Data Acquisition Modes are an essential part of FM1010 device, it is also highly configurable.

By configuration user defines how records will be saved and sent. There are three different modes: Home, Roaming and Unknown. All these modes with configured data acquisition and send frequencies depend on home or roaming operator and are switched when GSM operator changes from home to roaming or vice versa (e.g. vehicle passes through country boarder). Unknown profile switches on when there is no SIM card inserted or device can't find home operator or no operator reachable from roaming list.

If current GSM operator is defined as Home Operator, device will work in Home⁴ Data Acquisition mode, if current operator is defined as Roaming Operator, device will work in Roaming Data Acquisition mode, and if there is no SIM card inserted or it is damaged or device can't find home operator or no operator reachable from roaming list device will work in Unknown Acquisition mode.

This functionality allows having different AVL records acquire and send parameters values when object is moving or stands still. Vehicle moving or stop state is defined by Mode Switch parameter. There are 3 ways for FM1010 to switch between Vehicle on Stop and Vehicle Moving modes see section 5.7.

FM1010 allows having 6 different modes. Operational logic is shown in Figure 77 Data Acquisition Mode

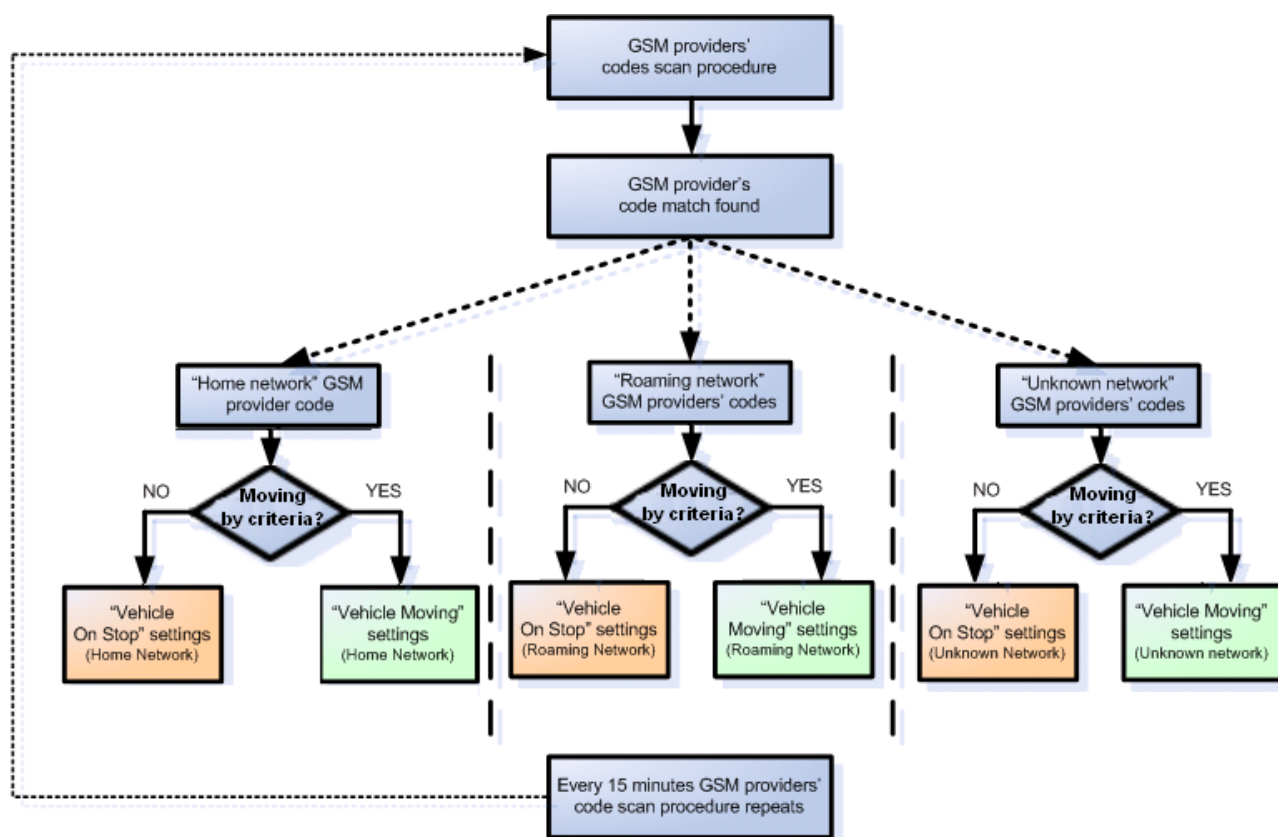

Figure 77 Data Acquisition Mode Operational logic

Operator search is performed every 15 minutes. Depending on current GSM operator, Home, Roaming or Unknown mode can be changed faster than every 15 minutes. This process is separate from operator search. Movement criteria are checked every second.

⁴ Home operator is searched automatically from 00.02.14 rev.02 firmware version.

System Records GSM DataAcquisitionModes > Home > Roaming > Unknown Features	Data Acquisition Modes : Home					
	Vehicle on STOP		Vehicle MOVING			
	Min Period:	3600	sec.	Min Period:	300	sec.
				Min Distance:	100	m.
				Min Angle:	10	deg.
	Min Saved Records:	1		Min Saved Records:	1	
Send Period:	1	sec.	Send Period:	1	sec.	
	GPRS Week Time				GPRS Week Time	

Figure 88 Data Acquisition Mode configuration

'Min Saved Records' defines minimum number of coordinates and I/O data that should be transferred with one connection to server. If FM1010 does not have enough records to send to server, it will check again after time interval defined in 'Sending Period'.

Send period – GPRS data sending to server period. Module makes attempts to send collected data to server every defined period. If it does not have enough records (depends on parameter Min. Saved Records described above), it tries again after defined time interval.

GPRS Week Time tab – most GSM billing systems charge number of bytes (kilobytes) transmitted per session. During the session, FM1010 makes connection and transmits data to a server. FM1010 tries to handle the session as much as possible; it never closes session by itself. Session can last for hours, days, weeks or session can be closed after every connection in certain GSM networks – this depends on GSM network provider. GPRS Context Week Time defines session re-establish schedule if session was closed by network. New GPRS context is opened if time is 10 minutes till time checked in table. Therefore if all boxes are checked, FM1010 is able to open new connection anytime. At scheduled time match FM1010 checks for GPRS session activity. If GPRS session is alive, FM1010 sends data to server according to Send period parameter. If it is not, FM1010 checks if it is able to re-establish the session.

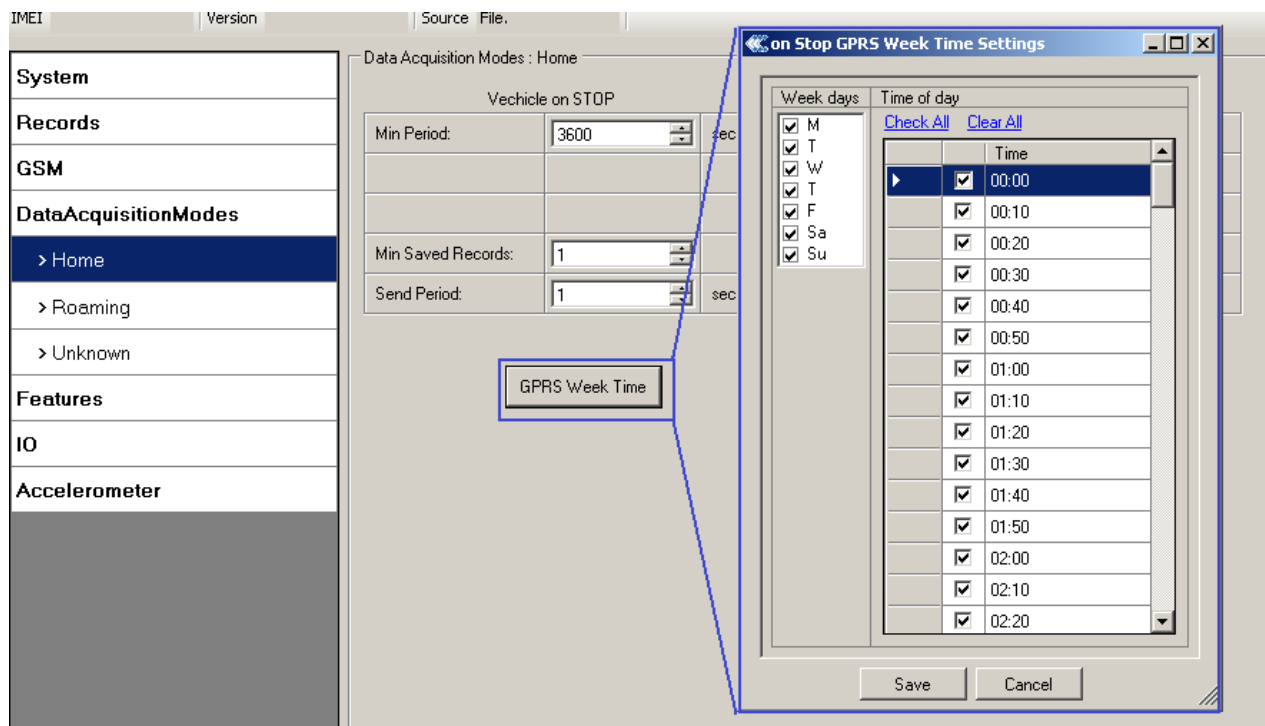

Figure 99 GPRS Week Time configuration

Device checks if the time between last saved record and current time is equal or higher than Time based acquire interval. If so, FM1010 saves record to memory. If not, FM1010 checks if the distance from last record to current record is equal or higher than Distance based acquire interval. If so, saves the record to memory. If not and speed is higher than 10km/h, then FM1010 checks if angle difference between last record and current record is equal or higher than Angle based acquire value. If so, saves the record to memory. These checks are performed every second.



Note: Keep in mind that FM1010 operates in **GMT:0** time zone, without daylight saving.

FM1010 is able to collect records using three methods at the same time: time, distance and angle based data acquisition:

Time based data acquiring (Min. period) – records are being acquired every time when defined interval of time passes. Entering zero disables data acquisition depending on time.

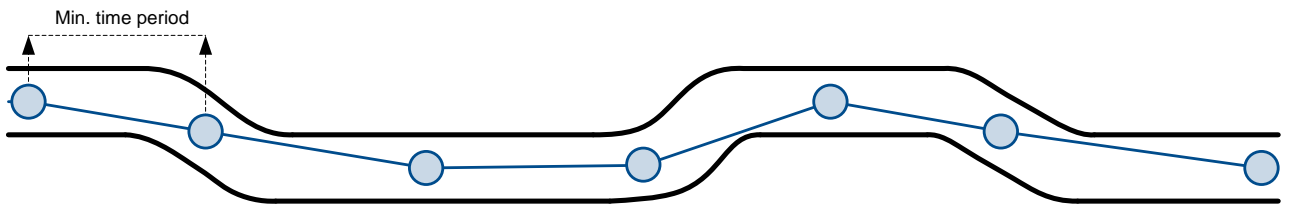

Distance based data acquiring (Min. distance) – records are being acquired when the distance between previous coordinate and current position is greater than defined parameter value. Entering zero disables data acquisition depending on distance.



Angle based data acquiring (Min. angle) – records are being acquired when angle difference between last recorded coordinate and current position is greater than defined value. Entering zero disables data acquisition depending on angle.

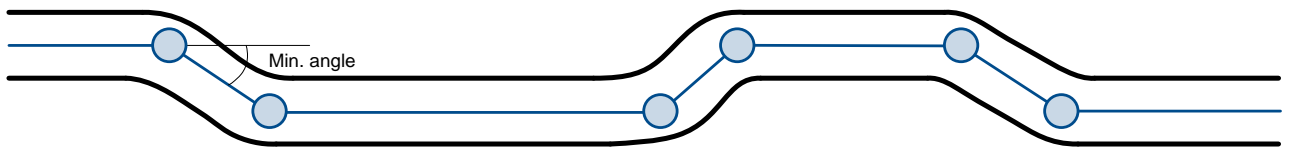

5.14 Features settings

- Scenarios settings

In Scenarios window two different scenarios are available.

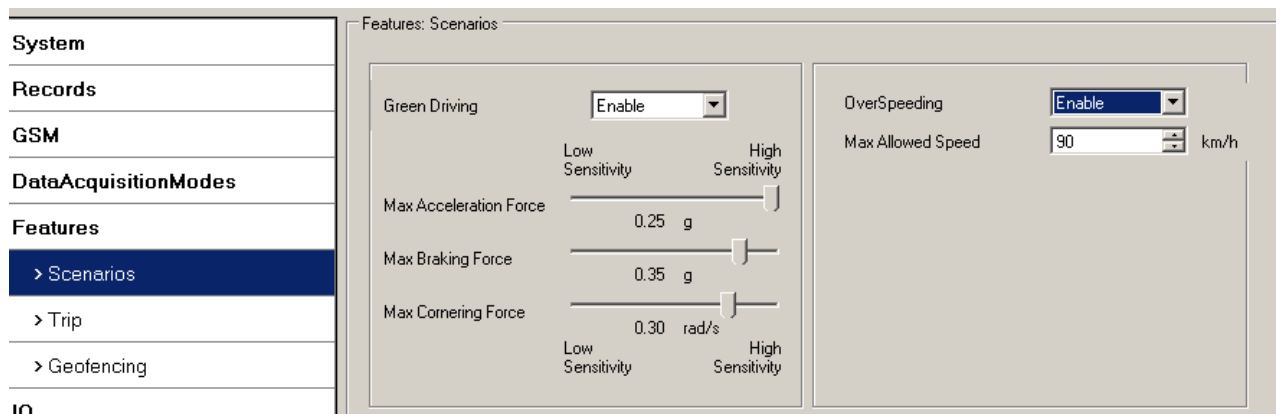

Figure 20 Scenarios configuration

- Green Driving
Eventual Record is generated when driving over allowed (configured) parameters.
- Over Speeding
Eventual Record is generated when driving over allowed (configured) speed and returning to normal speed.

- **Trip settings**

Trip window offers user to configure Trip feature. If Trip is enabled configuration of parameters are enabled.

Start Speed – GNSS speed has to be greater than the specified Start Speed in order to detect Trip Start.

Ignition Off Timeout – timeout to wait if ignition was off, to detect Trip stop.

Continuous distance counting – Not or Continuous can be chosen. For this feature I/O Odometer must be enabled.

If I/O Odometer is enabled and Continuous distance counting variable is set to Continuous, **Trip distance** is going to be counted continuously (**from Trip start to Trip stop**). This value is written to I/O Odometer value field. When Trip is over and next Trip begins, Odometer value is reset to zero. When the next trip starts counting continuously starts from the beginning again.

If I/O Odometer is enabled and Continuous Distance Counting variable is set “Not”, then the distance is going to be counted only between every record made. This value is written to I/O Odometer value field and reset to zero every new record until Trip stops. If later all Odometer values are summed up manually, the user gets the distance driven during the whole period of the Trip.

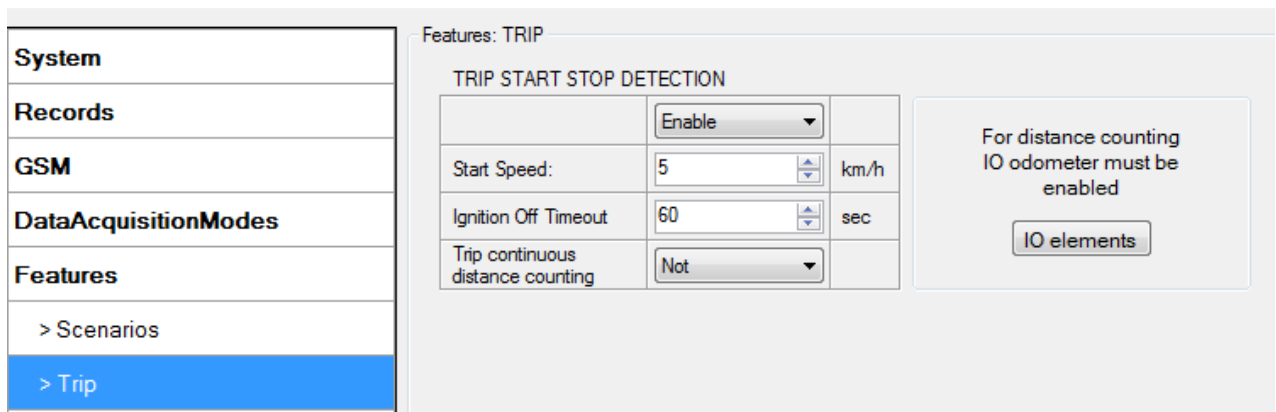

Features: TRIP		
TRIP START STOP DETECTION		
	Enable	
Start Speed:	5	km/h
Ignition Off Timeout	60	sec
Trip continuous distance counting	Not	

For distance counting IO odometer must be enabled

IO elements

Figure 101 Trip configuration

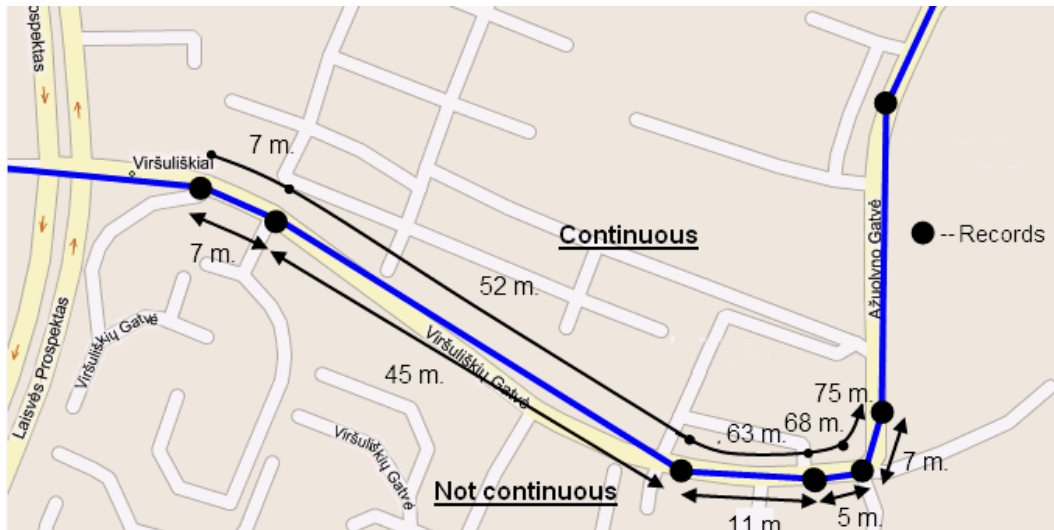

Figure 22 Trip continuous distance counting parameter example

- **Geofencing settings**

FM1010 has 5 configurable Geofence zones and it can generate an event when defined Geofence zone border is crossed.

Frame border – frame border is an additional border around Geofence zone. It is additional area around defined zone used to prevent false event recording when object stops on the border of the area and because of GNSS errors some records are made inside area and some – outside. Event is generated only when both borders are crossed. See figure 23 for details: track 1 is considered to have entered the area while track 2 is not.

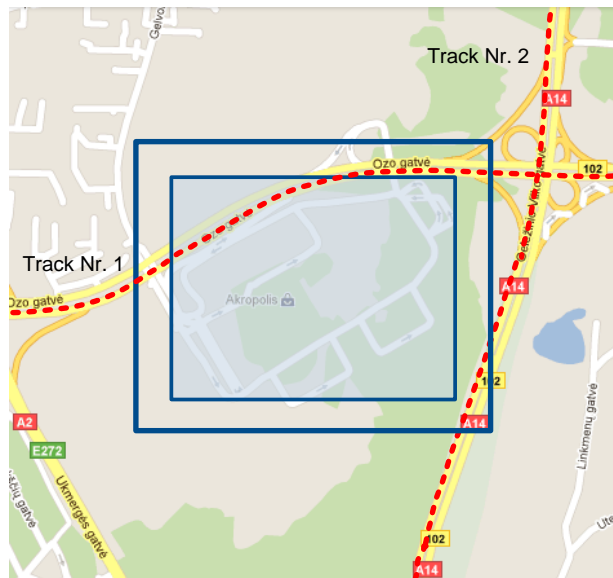

Figure 23 Geofence border

Shape – can be rectangle or circle.

Priority – priority of Geofence event: low, high or panic. These levels define priority of event information sending to server. See I/O element description for more details about priorities.

Generate event (On entrance, On exit, On Both) – choose when record will be generated;

X1 – geofence zone left bottom corner X coordinate (longitude);

- Y1 – geofence zone left bottom corner Y coordinate (latitude);
- X2 or R – geofence zone upper right corner X coordinate (longitude) or radius of circle when Circular zone is used (radius in meters);
- Y2 – geofence zone upper right corner Y coordinate (latitude);

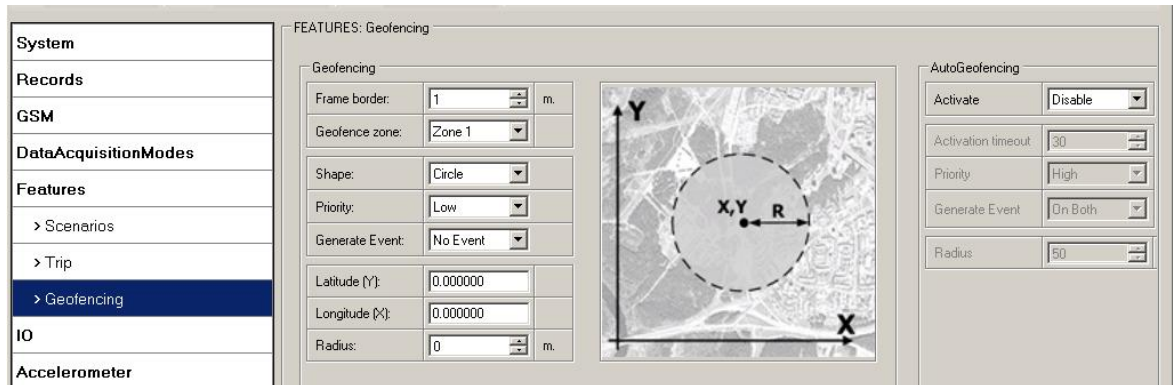

Figure 24 Geofence configuration

AutoGeofencing settings

AutoGeofence – the last known position after movement = off (“X on Stop Mode”).

If your car’s being taken away – you can be notified. The shape and size of the geofence zones are parameters. It is possibility to state whether entering in or out of the geofence triggers an asynchronous message.

AutoGeofencing option can be configured by following parameters visible in figure 25 below.

Activate – Enable or Disable AutoGeofence functionality.

Activation TMO – Time period before Geofence is activated after vehicle stops.

Priority – Priority of generated event, which will be applied to saved record.

Enter Event – Event generation on Geofence entrance.

Exit Event – Event generation on Geofence exit.

On Both - Event generation on Geofence entrance Or exit

Note that AutoGeofencing does not require entering coordinates, instead it requires GNSS visibility. If vehicle stopped and activation timeout has passed, an AutoGeofence will be created around vehicle’s last position with set Radius value. AutoGeofence event generation works the same as Geofencing mentioned above.

AutoGeofencing	
Activate	Disable
Activation timeout	60
Priority	High
Generate Event	On Exit
Radius	100 m.

Figure 115 AutoGeofence configuration



Note: FM1010 operates GMT:0 time without daylight saving.

- **SMS events**

SMS events functionality allows FM1010 to send a configured SMS when an event is triggered. This event can be triggered by:

- Green Driving
- OverSpeeding
- Trip start/stop
- Geofence
- AutoGeofence
- I/O event

When any of the above events is triggered, FM1010 sends a configured SMS message to a defined phone number. If SMS events is activated, but there are no numbers defined in SMS events PreDefined Numbers list (figure 26), then the device will not send any messages.

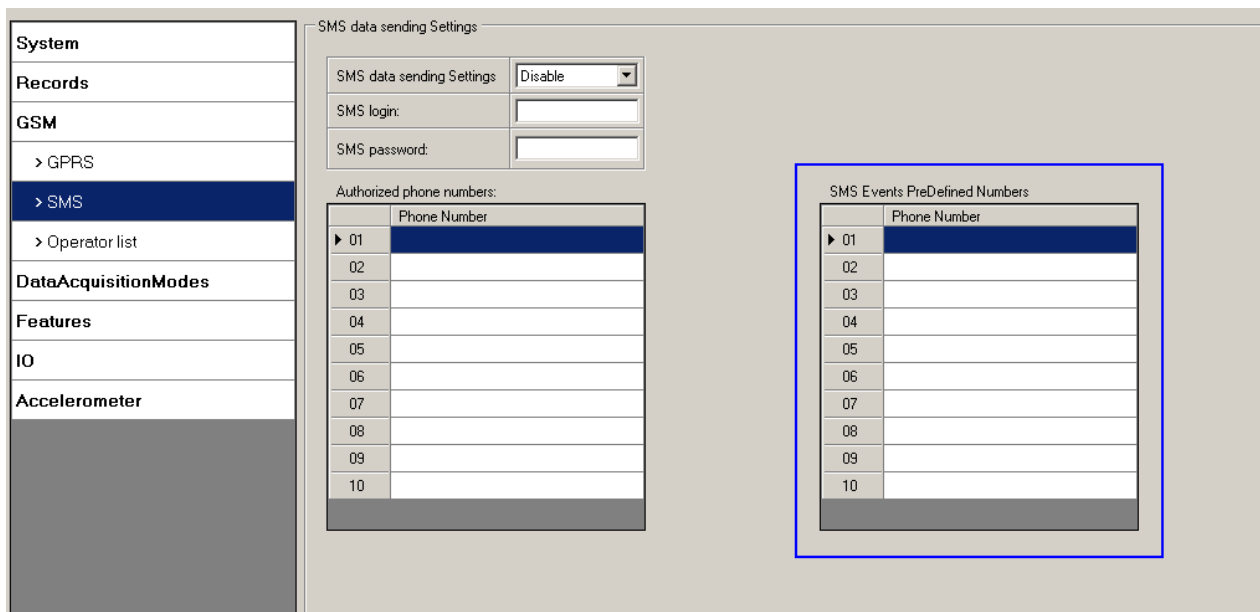

Figure 126 SMS Events PreDefined Numbers list

The sent SMS messages format is according to:

“Date Time EventText”

For example, if FM1010 is configured to send an SMS, when Digital Input 1 reaches High level, with priority High and configured to generate event on both range enter and exit (figure 27), then the sent SMS is:

“2013/7/1 12:00:00 Digital Input 1”

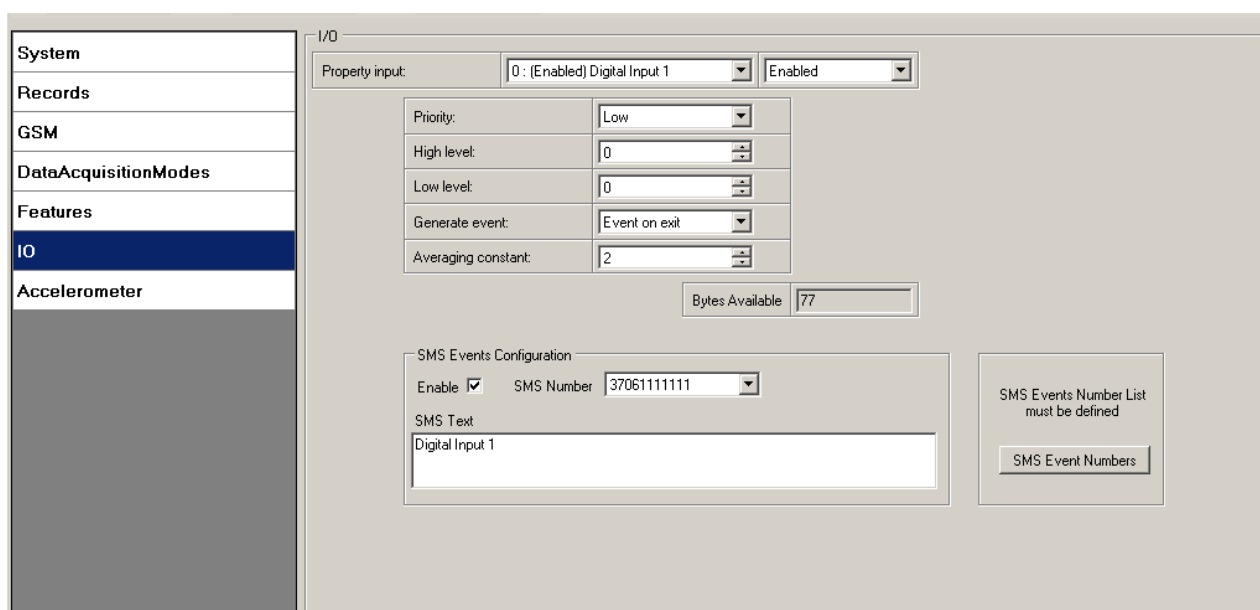

Figure 137 Configured Digital Input 1 SMS event

The SMS Text field can be altered and any text can be entered. Maximum message length is 90 symbols (numbers, letters and symbols in ASCII, except for comma “,”).



ATTENTION!

If FM1010 is in Deep Sleep mode and SMS event occurs with LOW priority (which does not wake up FM1010), then the device does not send the message. It is saved in device memory until it wakes up from Deep Sleep mode and GSM modem starts working normally. After it wakes up, all the messages that are saved in memory will be sent, but keep in mind that only 10 messages can be saved in memory – all other messages will not be saved, until there is room in device memory.

5.14..1 SMS events configuration

Scenarios

To configure SMS events for scenarios click scenarios window. Enabled scenarios will automatically appear near the SMS event window (figure 28). After enabling SMS events, different message texts can be written for different scenarios.

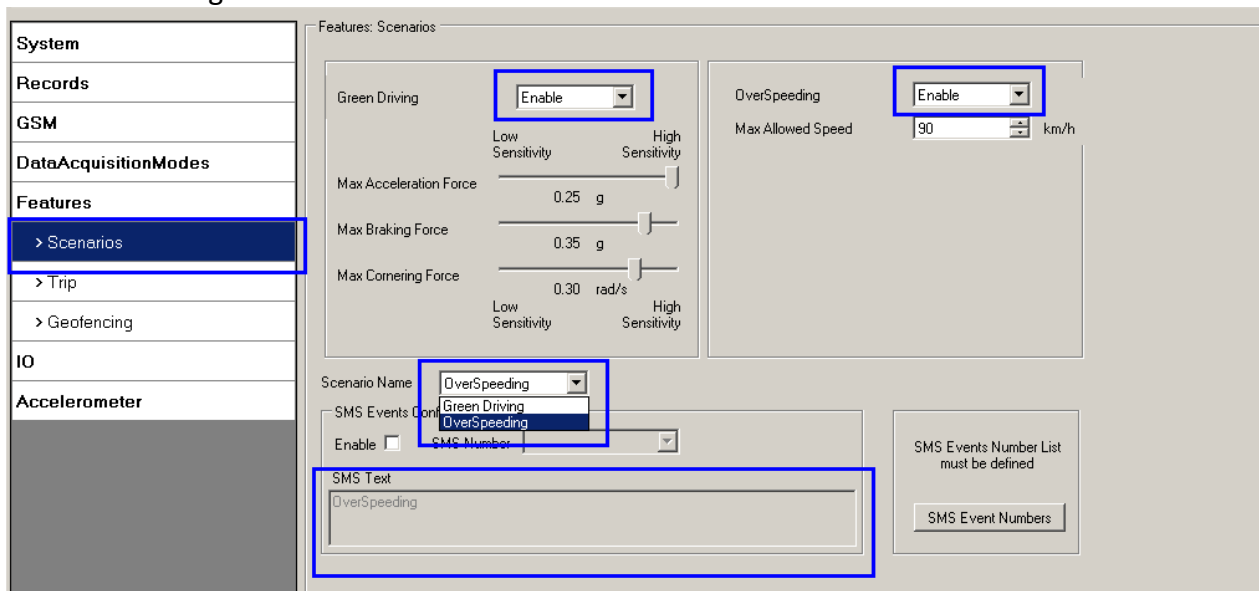

Figure 148 Scenarios SMS event configuration

When any of the scenarios events occurs, a text message will be sent to the predefined number.

Trip

In order to configure Trip SMS events click on Trip window. After enabling SMS Events (figure 29), trip event will be triggered and message sent, when Trip starts (GNSS speed exceeds the speed in Start Speed (ex. 5 km/h) and when Trip stops, that is ignition is turned off longer then the time written in Ignition Off Timeout (ex. 60 seconds).

System Records GSM DataAcquisitionModes Features > Scenarios > Trip > Geofencing IO	Features: TRIP TRIP START/STOP DETECTION <table border="1"> <tr> <td>Start Speed:</td> <td>5</td> <td>km/h</td> </tr> <tr> <td>Ignition Off Timeout:</td> <td>60</td> <td>sec</td> </tr> <tr> <td>Trip continuous distance counting:</td> <td>Not</td> <td></td> </tr> </table> <p>For distance counting IO odometer must be enabled <input type="button" value="IO elements"/></p> SMS Events Configuration Enable <input type="checkbox"/> SMS Number 123456789 SMS Text Trip <input type="button" value="SMS Event Numbers"/>	Start Speed:	5	km/h	Ignition Off Timeout:	60	sec	Trip continuous distance counting:	Not	
Start Speed:	5	km/h								
Ignition Off Timeout:	60	sec								
Trip continuous distance counting:	Not									

Figure 159 Trip Start/Stop SMS event configuration

Geofence

Geofence SMS event is triggered and message sent when the device exits and/or enters a configured Geofence zone. The Geofence zone must be configured to generate an event On Exit, On Enter or On Both (figure 30). If No Event is selected, then it is not possible to turn on SMS events. If several zones are created then SMS events can be turned on separately for each zone entering different text message.

System Records GSM DataAcquisitionModes Features > Scenarios > Trip > Geofencing IO Accelerometer	FEATURES: Geofencing Geofencing <table border="1"> <tr> <td>Frame border:</td> <td>10</td> <td>m.</td> </tr> <tr> <td>Geofence zone:</td> <td>Zone 1</td> <td></td> </tr> <tr> <td>Shape:</td> <td>Circle</td> <td></td> </tr> <tr> <td>Priority:</td> <td>Low</td> <td></td> </tr> <tr> <td>Generate Event:</td> <td>On Enter</td> <td></td> </tr> <tr> <td>Latitude (Y):</td> <td>0.000000</td> <td></td> </tr> <tr> <td>Longitude (X):</td> <td>0.000000</td> <td></td> </tr> <tr> <td>Radius:</td> <td>0</td> <td>m.</td> </tr> </table>  SMS Events Configuration Enable <input checked="" type="checkbox"/> SMS Number 123456789 SMS Text Geofence Zone 1	Frame border:	10	m.	Geofence zone:	Zone 1		Shape:	Circle		Priority:	Low		Generate Event:	On Enter		Latitude (Y):	0.000000		Longitude (X):	0.000000		Radius:	0	m.
Frame border:	10	m.																							
Geofence zone:	Zone 1																								
Shape:	Circle																								
Priority:	Low																								
Generate Event:	On Enter																								
Latitude (Y):	0.000000																								
Longitude (X):	0.000000																								
Radius:	0	m.																							

Figure 30 Geofence SMS event configuration

AutoGeofence

SMS events for AutoGeofence are configured the same as in Geofence. AutoGeofence and its SMS event configuration is next to Geofence configuration (figure 31).

AutoGeofencing

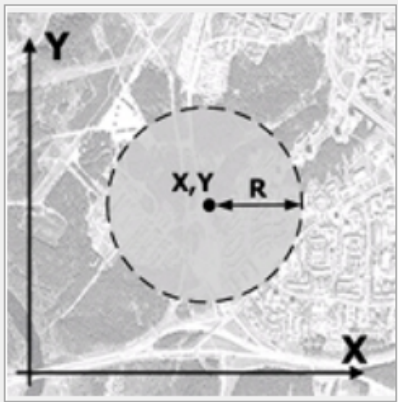
Activate: Enable

Activation timeout: 60

Priority: High

Generate Event: On Exit

Radius: 100 m.

SMS Events Configuration

Enable: SMS Number: 123456789

SMS Text: AutoGeofence

Figure 31 AutoGeofence SMS event configuration

I/O events

FM1010 sends SMS event message when a configured I/O property enters and/or exits its configured High/Low boundaries or Hysteresis event generation is chosen (Monitoring does not generate event, so SMS event could not be configured). Every IO element SMS event can be configured to send individual message to different numbers (figure 32).

System
Records
GSM
DataAcquisitionModes
Features
IO
Accelerometer

I/O

Property input: 0 : (Enabled) Digital Input 1 Enabled

Priority: Low

High level: 0

Low level: 0

Generate event: Event on exit

Averaging constant: 2

Bytes Available 71

SMS Events Configuration

Enable: SMS Number: 123456789

SMS Text: Digital Input 1

SMS Events Number List must be defined

SMS Event Numbers

Figure 162 I/O SMS event configuration

Accelerometer

Figure 173 accelerometer configuration

FM1010 has inbuilt accelerometer which can easily be configured for individual needs. Acceleration range specifies measurement range for accelerometer. The smaller the range the more precisely configuration can be set. Bigger ranges are only acceptable for harsh acceleration or crash detection.

Acceleration threshold specifies sensitivity at which movement is detected. The higher threshold, the harder is to change to movement state.

5.15 I/O settings

When no I/O element is enabled, AVL packet comes with GNSS information only. After enabling I/O element(s) AVL packet along with GNSS information contains current value(s) of enabled I/O element.

Permanent I/O elements
(are always sent to server if enabled)

Property ID	Property Name	Description
1	Digital Input Status 1	Logic: 0 / 1
2	GSM level	GSM signal level value in scale 1 – 5
3	Speed	Value in km/h, 0 – xxx km/h
4	External Power Voltage	Voltage: mV, 0 – 30 V
5	Data Mode	0 – home on stop, 1 – home on move, 2 – roaming on stop, 3 – roaming on move, 4 – unknown on stop, 5 – unknown on move
6	PDOP	Probability * 10; 0-500
7	HDOP	Probability * 10; 0-500
8	Odometer Value (Virtual Odometer)	Distance between two records: m
9	Deep Sleep	0 – not deep sleep mode, 1 – deep sleep mode
10	Cell ID	GSM base station ID
11	Area Code	Location Area code (LAC), it depends on GSM operator. It provides unique number which assigned to a set of base GSM stations. Max value: 65536
12	Movement Sensor	0 – not moving, 1 – moving.

13	GSM operator Code	Currently used GSM Operator code
14	Battery Voltage	Battery voltage: mV
15	Battery Current	Battery current: mA
23	Geofence zone 01	Event: 0 – target left zone, 1 – target entered zone
24	Geofence zone 02	Event: 0 – target left zone, 1 – target entered zone
25	Geofence zone 03	Event: 0 – target left zone, 1 – target entered zone
26	Geofence zone 04	Event: 0 – target left zone, 1 – target entered zone
27	Geofence zone 05	Event: 0 – target left zone, 1 – target entered zone
28	Auto Geofence	Event: 0 – target left zone, 1 – target entered zone
29	Trip	1 – trip start, 0 – trip stop
30	Green driving type	1 – harsh acceleration, 2 – harsh braking, 3 – harsh cornering
31	Green driving value	Depending on green driving type: if harsh acceleration or braking – $g \times 100$ (value 123 -> 1.23g), if harsh cornering – degrees (value in radians)
32	Over Speeding	At over speeding start km/h, at over speeding end km/h



There are two types of operations with Permanent I/O elements: simple monitoring and event generating. Monitoring method is used when current I/O information needed with regular GNSS coordinates. Event generating method is used when additional AVL packet is needed when current value of I/O exceeds predefined High and Low levels. I/O settings allow defining I/O event criteria.

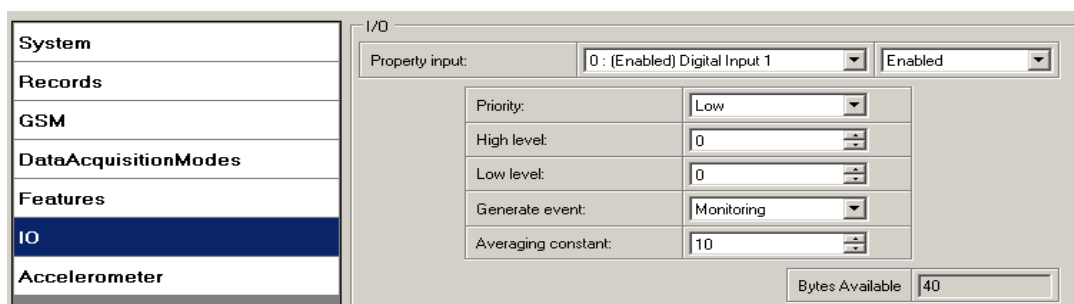

Figure 34 I/O settings

Enabled or disabled field – allows enabling I/O element so it is added to the data packet and is sent to the server. By default all I/O element are disabled and FM1010 records only GNSS coordinates.

Priority (AVL packet priority) can be low, high or panic. Regular packets are sent as Low priority records. When low priority event is triggered, FM1010 makes additional record with

indication that the reason for that was I/O element change. When High priority is selected, module makes additional record with high priority flag and sends event packet immediately to the server by GPRS. Panic priority triggers same actions as high priority, but if GPRS fails, it sends AVL packet using SMS mode if SMS is **enabled in SMS settings**.

High and Low levels – define I/O value range. If I/O value enters or exits this range, FM1010 generates event. “Generate event” parameter defines when to generate event – when value enters defined range, exits it or both.

Averaging constant – it is an I/O event delay parameter. In some applications there is no need to generate events on every I/O range enter/exit immediately. Sometimes it is necessary to wait some time interval before event generating. Averaging constant allows setting I/O event delay (averaging). If I/O value is entering or leaving predefined range, it must have same value for Averaging constant time. 1 Averaging constant value equals about 30 milliseconds. In Deep Sleep mode there is no Averaging.



Note: I/O element’s “Movement” Averaging constant is interpreted as Start Move Timeout in seconds (from 1 to 59).

Start Move Timeout – is a time interval required for accelerometer to be in the moving state, to consider vehicle as moving.

- **Event Generating**

Events happen when the value of enabled I/O intersects thresholds (enter, exit or on both) predefined by High and Low level thresholds. Table below defines all available values of I/O settings.

Setting	Value
Priority	low, high
High level	maximum threshold
Low level	minimum threshold
Generate event	on interval enter, on interval exit, on both enter and exit
Average constant	$1 - 2^{32}$ (4 Bytes)

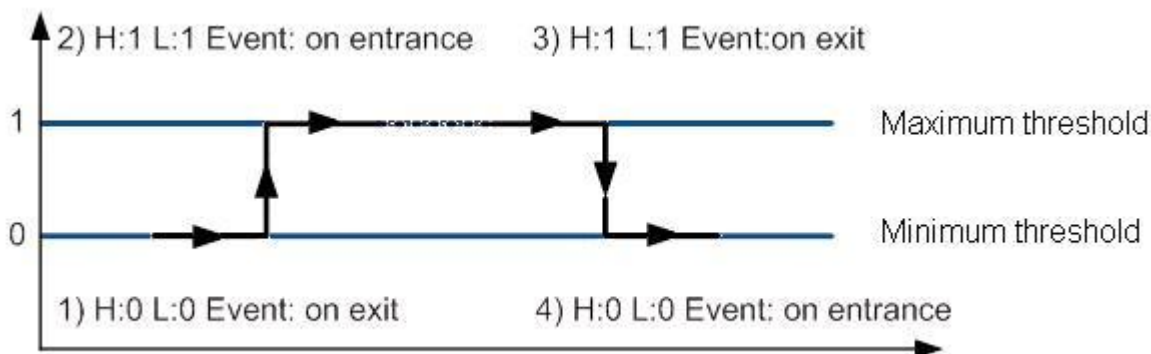

Figure 35 Digital Input event generation example

- Hysteresis

Priority:	Low
High level:	0
Low level:	0
Generate event:	Hysteresis
Averaging constant:	10

Figure 186 Hysteresis parameter configuration

I/O elements can generate events according to hysteresis algorithm. If I/O event operand “Hysteresis” is selected, events will be generated as it is shown in the illustration below (I/O speed is taken as I/O value example):

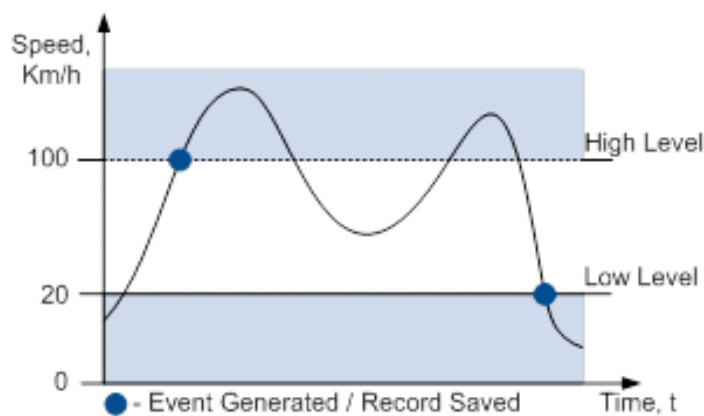

Figure 197 Event generation according hysteresis algorithm

6 SMS COMMAND LIST

Read chapter 5.11 to know how to construct a proper SMS message and send it to FM1010 device. All commands are case sensitive. While FM1010 operates in Deep Sleep mode and user tries to send SMS message it cannot arrive to FM1010 device, because GSM/GPRS module is disabled most of the time (wake up depends on Send Period parameter). FM1010 will receive the SMS when it wakes up (exits deep sleep mode).

6.1 SMS command list

Command	Description	Response
getstatus	Modem Status information	Yes
getweektime	Current device time, Day of Week and amount of minutes passed since start of week	Yes
getops	List of currently available GSM operator	Yes
getcfgtime	Date and Time of last successful configuration	Yes
ggps	Google Map Link information	Yes

getgps	Current GNSS data and time	Yes
getinfo	Device runtime system information	Yes
getver	Device / Modem / Code version information	Yes
allver	Device / HW version information	
cpureset	Reset CPU	No
resetprof	Reset all FLASH1 profile configuration to default profile	Yes
deleterecords	Delete all records saved on FLASH	Yes
getio	Readout digital input 1	Yes
radio #	Readout input value according entered ID, # - ID value	Yes
getparam #	Readout parameter value according entered ID. # - ID value.	Yes
setparam # #	Set parameter value according entered ID and Value. 1.# - ID value. 2.# - New Parameter Value	Yes
flush #,#,#,#,#,#,#	Initiates all data sending to specified target server 1.# - IMEI 2.# - APN 3.# - LOGIN 4.# - PASS 5.# - IP 6.# - PORT 7.# - MODE (0-TCP/1-UDP)	Yes
banlist	Banned operators information	Yes
crashlog	Device last information before unexpected reset	Yes
bbread	Device debug information	Yes
delete_all_sms	Deletes all SMS	No
defevt	Reset SMS Events configuration to default	Yes
battery	Battery information	Yes

- **getstatus**

Response details	Description
Data Link	Indicate module connection to server at the moment: 0 – Not connected, 1 – connected
GPRS	Indicate if GPRS is available at the moment
Phone	Voice Call status: 0 – ready, 1 – unavailable, 2 – unknown, 3 – ringing, 4 – call in progress, 5 – asleep
SIM	SIM Status: 0-ready, 1-pin, 2-puk, 3-pin2, 4-puk2
OP	Connected to GSM Operator: numerical id of operator
Signal	GSM Signal Quality [0-5]
NewSMS	Indicate if new message received
Roaming	0 – Home Network, 1 – roaming
SMSFull	SMS storage is full? 0 – ok, 1 – SMS storage full
LAC	GSM Tower Location Area Code
Cell ID	GSM Tower Cell ID Code

Example: Data Link: 0 GPRS: 1 Phone: 0 SIM: 0 OP: 24602 Signal: 5 NewSMS: 0 Roaming: 0 SMSFull: 0 LAC: 1 Cell ID: 864

- **getweektime**

Response details	Description
Clock Sync	Indicates system clock synchronization status. 0 – System is not synchronized, 1 – System synchronized
DOW	Day Of Week – indicates current day of week starting from 0 – Monday, 1 – Tuesday, etc.
Time	Indicates current GMT time
WeekTime	Indicates time in minutes starting from Monday 00:00 GMT

Example: Clock Sync: 1 DOW: 4 Time 12:58 Weektime: 6538

- **getops**

Response details	Description
LIST	Returns list of current available allowed operators.

Example: GSM OP LIST: 0. 24602

- **getcfgtime**

Response details	Description
Date/Time	Returns last performed configuration date and time.

Example: Last Configuration was performed on: 2010.4.15 5:45:19

- **ggps**

Response details	Description
D	Date
T	Time
S	Actual Speed
C	Latitude (Last good Latitude), Longitude (Last good Longitude)
Url	Google Maps Link

Example: D:2013/7/4 T:0:0:0 S:0 C:0, 0 Url: <http://maps.google.com/?q=0,0&om=1speed:0>

- **getgps**

Response details	Description
GNSS	Indicates valid (1) or invalid (0) GNSS data
Sat	Count of currently available satellites
Lat	Latitude (Last good Latitude)
Long	Longitude (Last good Longitude)
Alt	Altitude
Speed	Ground speed, km/h

Dir	Ground direction, degrees
Date	Current date
Time	Current GMT time

Example: GNSS:1 Sat:7 Lat:54.71473 Long:25.30304 Alt:147 Speed:0 Dir:77 Date: 2007/8/24 Time: 13:4:36

- **getinfo**

Response details	Description
INI	Device Initialization Time
RTC	RTC Time
RST	Restart Counter
ERR	Error Counter
SR	Number of Sent Records
BR	Number of broken records
CF	Profile CRC Fail counter
FG	Failed GPRS counter
FL	Failed link counter
UT	UPD Timeout counter
SMS	Sent SMS Counter
NOGNSS	No GNSS Timer
GNSS	GNSS receiver state. 0 – OFF, 1 – restarting, 2 – ON but no fix, 3 – ON and operational, 4 – sleep mode
SAT	Average satellites
RS	Reset Source Identification 1 – Low Power, 2 – W Watchdog, 3 – I Watchdog, 4 – Software reset, 5 – Power On, 6 - Pin Reset
MD	Data Mode state. 0 – Home and Stop, 1 – Home and Moving, 2 – Roaming and Stop, 3 – Roaming and Moving, 4 – Unknown and Stop, 5 – Unknown and Moving

Example: INI:2007/8/24 10:15 RTC:2007/8/24 12:43 RST:2 ERR:11 SR:182 BR:0 CF:0 FG:0 FL:0 UT:0 SMS:2 NOGNSS:0:0 GNSS:3 SAT:7 RS:5 MD:0

- **getver**

Response details	Description
Code Ver	Firmware version
Rev	Firmware revision
Device IMEI	IMEI
Device ID	Device ID is used to detect by server which type of configuration to load
Bootloader Ver	Bootloader Version
Modem App Ver	Version of modem application

Example: Code Ver:00.00.13 Rev:0 Device IMEI:X Device ID:00000E Bootloader Ver: 00.61
Modem APP Ver:TM11Q_R_01.03.05.01_002

- **allver**

Response details	Description
1	Device name
2	Firmware version
3	Firmware revision
4	IMEI
5	Firmware compile date
6	Bootloader version
7	Device ID
8	Flash Manufacturer ID
9	Flash Capacity
10	Version of modem application
11	HW revision voltage
12	GNSS module description

FM1010,00.00.13,0,356307044051570,Jul4
2013,00.61,0E,20,18,1.05.01,381,GGG303_002,,,,,

- **getio**

Response details	Description
DI1	Digital Input 1 state

Example: DI1:0

- **readio #**

Response details	Description
ID	I/O element ID
Value	I/O Element value

Example: I/O ID:3 Value:0

- **getparam #####**

Read parameter value. ID consists of 3 or 4 digits. Detailed list of parameters and IDs can be found in chapter number 8 "Parameter List"

Example: 'getparam 1245' command will request server IP address.

- **setparam #####**

Sets new value for parameter. ID consists of 3 or 4 digits. Detailed list of parameters and IDs can be found in chapter number 8 "Parameter List"

Example: 'setparam 1245 127.0.0.1' will change configured IP address.

- **flush #,#,#,#,#,#,#**

Initiates all data sending by GPRS to specified target server. Comma separated parameters go as numbered:

- 1.# - IMEI
- 2.# - APN
- 3.# - GPRS LOGIN
- 4.# - GPRS PASSWORD
- 5.# - IP
- 6.# - PORT
- 7.# - MODE (0-TCP/1-UDP)

Parameters are separated by comma (no spaces needed). In case you don't need to enter parameter (Login/Pass) – do not put space, simply put comma and write next parameter.

Example: opa opa flush 353976012555151,banga,,,212.47.99.62,12050,0

Response details	Description
FLUSH SMS Accepted	FLUSH SMS Accepted
# records found on FLASH	Number of records found on FLASH
Minimum Records to Send: #	Number of minimum saved records to send
GPRS Enabled: #	State of the GPRS connection, 0 – disabled; 1 – enabled
Time Sync: #	Indicates time synchronization on the device, 0 – not synchronized; 1 – synchronized

Example: FLUSH SMS Accepted. 11 records found on FLASH. Minimum Records to Send: 1. GPRS Enabled: 1. Time Sync: 1.

- **banlist**

Gives a list of all banned operators.

Example when no operators are banned: 0000.00s.0.000

- **crashlog**

Gives the last information before the device has crashed for unexpected reasons. It is useful when the device acts unexpectedly or restarts for unexplained reasons.

Example if no unexpected reset: "Crash: "

Example if unexpected reset was detected: "Crash: 3051,3052,3053".

7 Debug mode

FM1010 is able to transmit its current state when connected to PC using USB cable. It is used to detect errors and provide information to possible solutions when operating as unexpected. Download Terminal from:

<http://avl1.teltonika.lt/Downloads/Software/Terminal.zip>.

After launching terminal choose baud rate 115200 and hardware control – none. Select COM port which is assigned to “Virtual COM Port”. Click on ‘Start Log’ button and save a new file. Then click ‘Connect’ to start receiving messages from FM1010 .

Also you can log NMEA data directly. To get NMEA data, simply enter the following command into the command field: **.log_nmea:1\$0a**.

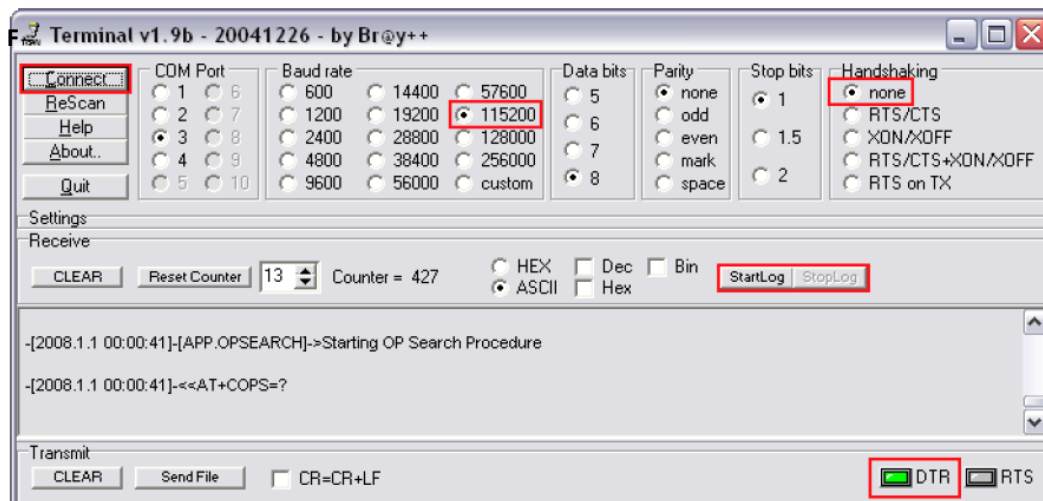

Figure 38 Terminal window for logging

8 Parameter List

8.1 Parameters value types

- S8 – Signed Char
- S8[n] – String of *n* Char
- U8 – Unsigned Char
- U16 – Unsigned Short
- S32 – Signed Integer
- U32 – Unsigned Integer
- U64 – Unsigned Long Long Integer

8.2 System parameters

- **Sleep Mode (ID=1000)**

Device has two sleep modes: sleep and deep sleep mode. While sleep is disabled (value 0) module will never enter sleep mode, in sleep mode (value 1) module reduces level of power usage by turning GNSS module to sleep, in deep sleep mode (value 2) module turns GNSS module to sleep and switch GSM module off (note, that FM1010 do not receive SMS while in deep sleep).

Minimum value	Maximum value	Recommended value	Goes with (depends on) parameters	Value type
0	2	-		U8

- **Sleep timeout (ID=1001)**

Sleep timeout is time after which FM1010 goes to sleep or deep sleep if other requirements are met. It is measured in minutes.

Minimum value	Maximum value	Recommended value	Goes with (depends on) parameters	Value type
1	3000	-		U8

- **Mode Switch Source (ID=1002)**

Device can operate and change its working mode according to motion detection source: ignition (value 0), movement (value 1), GNSS (value 2).

Minimum value	Maximum value	Recommended value	Goes with (depends on) parameters	Value type
0	2	-		U8

- **Ignition Source (ID=1003)**

Device can operate and change its working mode according to motion detection source: Power Voltage (value 0), Digital Input 1 (value 1), movement (value 2).

Minimum value	Maximum value	Recommended value	Goes with (depends on) parameters	Value type
0	2	-	Power Voltage Low Level (ID=1006) Power Voltage Level High Level (1007)	U8

- **Saving/Sending without time synchronization (ID=1005)**

When this feature is enabled (value = 1), then records can be saved and sent to server without time synchronization.

Minimum value	Maximum value	Recommended value	Goes with (depends on) parameters	Value type
0	1	1		U8

- **Power Voltage Low Level (ID=1006)**

When ignition source is selected as Power Voltage Low level for ignition detection must be set.

Minimum value	Maximum value	Recommended value	Goes with (depends on) parameters	Value type
0	30000	-	Ignition Source (ID=1003) Power Voltage Level High Level (1007)	U16

- **Power Voltage High Level (ID=1007)**

When ignition source is selected as Power Voltage High level for ignition detection must be set.

Minimum	Maximum	Recommended	Goes with (depends on)	Value

value	value	value	parameters	type
0	30000	-	Ignition Source (ID=1003) Power Voltage Level Low Level (1006)	U16

8.3 Records parameters

- **Sorting (ID=1010)**

Record sorting parameter is responsible for record sorting order. Value of 0 arranging data starting from newest, while value of 1 arranging data starting from oldest.

Minimum value	Maximum value	Recommended value	Goes with (depends on) parameters	Value type
0	1	-		U8

- **Active Data Link Timeout (ID=1011)**

Defines for how many seconds device will keep connection to the server after successful data transfer while waiting for a new record.

Minimum value	Maximum value	Recommended value	Goes with (depends on) parameters	Value type
0	259200	-		U32

- **Server Response Timeout (ID=1012)**

Defines time period (in seconds) for server response to sent records.

Minimum value	Maximum value	Recommended value	Goes with (depends on) parameters	Value type
1	300	-		U8



ATTENTION! Some GSM operators may disconnect the device from an active data link if the device doesn't send any data for a very long time, even if active data link timeout is set to maximum value. The amount of time that an operator keeps the link open depends solely on the operator. For example, if active data link timeout is set to maximum, 259200 seconds (72 hours), and the device sends data to server every 86400 seconds (24 hours), the operator might disconnect the link earlier and the device will have to connect to the server anew. This may cost extra, depending on the operator GPRS data charge. It is strongly recommended, when using active data link timeout, that data sending to the server should not be very rare (24 hours or more). If data sending is more frequent, then the operator will not disconnect the device from the server.

8.4 GSM parameters

- **GPRS content activation (ID=1240)**

Parameter allows or does not allow GPRS usage. If GPRS is not allowed value is 0, if GPRS is allowed value is 1.

Minimum value	Maximum value	Recommended value	Goes with (depends on) parameters	Value type
0	1	-	APN Name (ID=1242) APN username (ID=1243) APN Password (ID=1244)	S8

- **APN Name (ID=1242)**

Parameter defines GPRS Access Point Name.

Minimum value	Maximum value	Recommended value	Goes with (depends on) parameters	Value type
Empty	32 char string	-	GPRS content activation (ID=1240) APN username (ID=1243) APN Password (ID=1244)	S8[32]

- **APN username (ID=1243)**

Parameter defines APN username. In case operator does not use username for login, value should be empty.

Minimum value	Maximum value	Recommended value	Goes with (depends on) parameters	Value type
Empty	30 char string	-	GPRS content activation (ID=1240) APN Name (ID=1242) APN Password (ID=1244)	S8[30]

- **APN Password (ID=1244)**

Parameter defines APN password. In case operator does not use password for login, value should be empty.

Minimum value	Maximum value	Recommended value	Goes with (depends on) parameters	Value type
Empty	30 char string	-	GPRS content activation (ID=1240) APN Name (ID=1242) APN username (ID=1243)	S8[30]

- **Domain (ID=1245)**

Parameter defines AVL data destination server IP address. Example: 212.47.99.62

Minimum value	Maximum value	Recommended value	Goes with (depends on) parameters	Value type

0	50 char string	-	GPRS content activation (ID=1240) Domain (ID=1245)	S8[16]
---	----------------	---	---	--------

- **Target Server Port (ID=1246)**

Parameter defines AVL data destination server port number. Example: 12050

Minimum value	Maximum value	Recommended value	Goes with (depends on) parameters	Value type
Empty	65535	-	GPRS content activation (ID=1240) Target Server Port (ID=1246)	U16

- **Protocol (ID=1247)**

Parameter defines GPRS data transport protocol. Module can use TCP or UDP transport protocol to send data to server. For TCP protocol value is 0, for UDP protocol value is 1.

Minimum value	Maximum value	Recommended value	Goes with (depends on) parameters	Value type
0	1	-	GPRS content activation (ID=1240)	U8

- **SMS Login (ID=1252)**

User login is used to ensure module security. Used in every SMS that is sent to device. Example: ba321

Minimum value	Maximum value	Recommended value	Goes with (depends on) parameters	Value type
Empty	5 char	-	SMS Password (ID=1253)	S8[5]

- **SMS Password (ID=1253)**

User password is used to ensure module security. Used in every SMS that is sent to device. Example: ab123

Minimum value	Maximum value	Recommended value	Goes with (depends on) parameters	Value type
Empty	5 char	-		S8[5]

- **SMS data sending settings (ID=1250)**

Parameter allows or does not allow sending AVL data using binary SMS. If SMS use is not allowed value is 0 and 1 if SMS use is allowed.

Minimum value	Maximum value	Recommended value	Goes with (depends on) parameters	Value type
0	1	-	Error! Reference source not found.	S8

- **Authorized phone numbers (ID=1260-1269)**

If at least one number is entered then only those number can send messages to device. Number must be entered without "+" or "00".

Example: 37060012346

Minimum value	Maximum value	Recommended value	Goes with (depends on) parameters	Value type
1 digit	16 digits	-		S8[17]

If SMS data sending is enabled (ID=1250) first value in a list is server GSM number. The SMS with panic priority will be sent

- **SMS Event PreDefined Numbers (ID=150-159)**

In this field are written GSM numbers, to which will be sent “Event SMS” text message. Number must be entered without “+” or “00”.

Example: 37060012346

Minimum value	Maximum value	Recommended value	Goes with (depends on) parameters	Value type
1 digit	16 digits	-		S8[17]

8.5 Data Acquisition Modes parameters

- **Home Network GSM operator code “Vehicle on STOP” parameters**

8.5.1 Min Period (ID=1540)

This parameter indicates time interval in seconds in order to acquire new record. If value is 0 it means no records by min period will be saved.

Minimum value	Maximum value	Recommended value	Goes with (depends on) parameters	Value type
0	2592000	-		U32

8.5.2 Min Saved Records (ID=1543)

This parameter defines minimum number of records in one data packet that can be sent to server. It has higher priority than Data Send Period (ID=1544).

Minimum value	Maximum value	Recommended value	Goes with (depends on) parameters	Value type
1	255	1	GPRS Week Time (ID=1545)	U8

8.5.3 Send Period (ID=1544)

This parameter indicates frequency (time interval in seconds) of sending data to server.

Minimum value	Maximum value	Recommended value	Goes with (depends on) parameters	Value type
0	2592000	-	Min Saved Records (ID=1543) GPRS Week Time (ID=1545)	U32

8.5.4 GPRS Week Time (ID=1545)

This parameter manages when it is allowed to open GPRS context. When module starts it is prohibited to open the context. When modem’s GPRS context is closing (for example changing network) it is allowed to open it only at a defined time. It is possible to allow connections every 10 minutes up to once per day.

Example value: 7F,FF,FF,FF,FF,FF,FF,FF,FF,FF,FF,FF,FF,FF,FF,FF,FF,FF

Schedule parameter format:

Time is defined as 19 byte array. First byte of array defines week days; the rest 18 bytes define timestamps with 10 minute interval. In first byte, first bit (LSB) defines if module should connect to GPRS (send SMS) on Monday, second bit – on Tuesday and so on up to seventh bit – which means Sunday. Eighth bit (MSB) is not used. If bits value is 0 then device is not allowed to open GPRS context, but if it is already open – does not close it. If value is 1 it will work as day minutes are defined in rest of the bytes. Day’s minutes are defined by 18 bytes (144 bits). Every nth bit (beginning from the first bit (LSB) and ending 18 bytes 8th bit (MSB)) indicates every 10th minute of the day (day has 1440 minutes).

Sample: GPRS will be allowed on Monday to Friday at 8:00 and 16:00 GMT. The following value should be configured:

00011111 00000000 00000000 00000000 00000000 00000000 00000000 00000001 00000000 00000000
00000000 00000000 00000000 00000000 00000001 00000000 00000000 00000000 00000000 00000000

Red bits indicate that GPRS will be allowed every day except Saturdays and Sundays. Blue bits indicate 480 and 720 minutes (480min = 8h and 720min = 16h). So the parameter value should be: 1F,00,00,00,00,00,00,01,00,00,00,00,00,01,00,00,00,00

It should be sent as UTF8 encoded string.

- Home Network GSM operator code “Vehicle MOVING” parameters

8.5..5 Min Period (ID=1550)

This parameter indicates time interval in seconds in order to acquire new record. If value is 0 it means no records by min period will be saved.

Minimum value	Maximum value	Recommended value	Goes with (depends on) parameters	Value type
0	2592000	-	Min Distance (ID=1551) Min Angle (ID=1552) GPRS Week Time (ID=1555)	U32

8.5..6 Min Distance (ID=1551)

This parameter indicates distance in meters in order to acquire new record. Record is stored when the distance between previous records is greater than parameters value. If value is 0 it means no records by min distance will be saved.

Minimum value	Maximum value	Recommended value	Goes with (depends on) parameters	Value type
0	65535	-	Min Period (ID=1550) Min Angle (ID=1552) GPRS Week Time (ID=1555)	U32

8.5..7 Min Angle (ID=1552)

This parameter indicates angle in degrees in order to acquire new record. If angle difference between last recorded coordinate and current position is greater than defined value, new record is stored. This parameter is operational, when speed is higher than 10km/h. If value is 0 it means no records by min angle will be saved.

Minimum	Maximum	Recommended	Goes with (depends on)	Value
---------	---------	-------------	------------------------	-------

value	value	value	parameters	type
0	180	-	Min Period (ID=1550) Min Distance (ID=1551) GPRS Week Time (ID=1555)	U16

8.5..8 Min Saved Records (ID=1553)

This parameter defines minimum number of records in one data packet that can be sent to server. It has higher priority than Data Send Period (ID=1554).

Minimum value	Maximum value	Recommended value	Goes with (depends on) parameters	Value type
1	255	1	Min Period (ID=1550) Min Distance (ID=1551) Min Angle (ID=1552) GPRS Week Time (ID=1555)	U8

8.5..9 Send Period (ID=1554)

This parameter indicates frequency (time interval in seconds) of sending data to server.

Minimum value	Maximum value	Recommended value	Goes with (depends on) parameters	Value type
0	2592000	-	GPRS Week Time (ID=1545)	U32

8.5..10 GPRS Week Time (ID=1555)

Read 8.5..4.

- Roaming Network GSM operator code “Vehicle on STOP” parameters

8.5..11 Min Period (ID=1560)

This parameter indicates time interval in seconds in order to acquire new record. If value is 0 it means no records by min period will be saved.

Minimum value	Maximum value	Recommended value	Goes with (depends on) parameters	Value type
0	2592000	-		U32

8.5..12 Min Saved Records (ID=1563)

This parameter defines minimum number of records in one data packet that can be sent to server. It has higher priority than Data Send Period (ID=1564).

Minimum value	Maximum value	Recommended value	Goes with (depends on) parameters	Value type
1	255	1	GPRS Week Time (ID=1565)	U8

8.5..13 Send Period (ID=1564)

This parameter indicates frequency (time interval in seconds) of sending data to server.

Minimum value	Maximum value	Recommended value	Goes with (depends on) parameters	Value type
0	2592000	-	Min Saved Records (ID=1563) GPRS Week Time (ID=1565)	U32

8.5..14 GPRS Week Time (ID=1565)

Read chapter 8.5..4.

- Roaming Network GSM operator code “Vehicle MOVING” parameters

8.5..15 Min Period (ID=1570)

This parameter indicates time interval in seconds in order to acquire new record. If value is 0 it means no records by min period will be saved.

Minimum value	Maximum value	Recommended value	Goes with (depends on) parameters	Value type
0	2592000	-	Min Distance (ID=1571) Min Angle (ID=1572) GPRS Week Time (ID=1575)	U32

8.5..16 Min Distance (ID=1571)

This parameter indicates distance in meters in order to acquire new record. Record is stored when the distance between previous records is greater than parameter’s value. If value is 0 it means no records by min distance will be saved.

Minimum value	Maximum value	Recommended value	Goes with (depends on) parameters	Value type
0	65535	-	Min Period (ID=1570) Min Angle (ID=1572) GPRS Week Time (ID=1575)	U32

8.5..17 Min Angle (ID=1572)

This parameter indicates angle in degrees in order to acquire new record. If angle difference between last recorded coordinate and current position is greater than defined value, new record is stored. This parameter is operational, when speed is higher than 10km/h. If value is 0 it means no records by min angle will be saved.

Minimum value	Maximum value	Recommended value	Goes with (depends on) parameters	Value type
0	180	-	Min Period (ID=1570) Min Angle (ID=1572) GPRS Week Time (ID=1575)	U16

8.5..18 Min Saved Records (ID=1573)

This parameter defines minimum number of records in one data packet that can be sent to server. It has higher priority than Data Send Period (ID=1574).

Minimum value	Maximum value	Recommended value	Goes with (depends on) parameters	Value type
1	255	1	Min Period (ID=1570) Min Distance (ID=1571) Min Angle (ID=1572) GPRS Week Time (ID=1575)	U8

8.5..19 Send Period (ID=1574)

This parameter indicates frequency (time interval in seconds) of sending data to server.

Minimum	Maximum	Recommended	Goes with (depends on)	Value
---------	---------	-------------	------------------------	-------

value	value	value	parameters	type
0	2592000	-	Min Saved Records (ID=1573) GPRS Week Time (ID=1575)	U32

8.5..20 GPRS Week Time (ID=1575)

Read chapter 8.5..4.

- **Unknown Network GSM operator code “Vehicle on STOP” parameters**

8.5..21 Min Period (ID=1580)

This parameter indicates time interval in seconds in order to acquire new record. If value is 0 it means no records by min period will be saved.

Minimum value	Maximum value	Recommended value	Goes with (depends on) parameters	Value type
0	2592000	-		U32

8.5..22 Min Saved Records (ID=1583)

This parameter defines minimum number of records in one data packet that can be sent to server. It has higher priority than Data Send Period (ID=1584).

Minimum value	Maximum value	Recommended value	Goes with (depends on) parameters	Value type
1	255	1	GPRS Week Time (ID=1585)	U8

8.5..23 Send Period (ID=1584)

This parameter indicates frequency (time interval in seconds) of sending data to server.

Minimum value	Maximum value	Recommended value	Goes with (depends on) parameters	Value type
0	2592000	-	Min Saved Records (ID=1583) GPRS Week Time (ID=1585)	U32

8.5..24 GPRS Week Time (ID=1585)

Read chapter 8.5..4.

- **Unknown Network GSM operator code “Vehicle MOVING” parameters**

8.5..25 Min Period (ID=1590)

This parameter indicates time interval in seconds in order to acquire new record. If value is 0 it means no records by min period will be saved.

Minimum value	Maximum value	Recommended value	Goes with (depends on) parameters	Value type
0	2592000	-	Min Distance (ID=1571) Min Angle (ID=1572) GPRS Week Time (ID=1575)	U32

8.5..26 Min Distance (ID=1591)

This parameter indicates distance in meters in order to acquire new record. Record is stored when the distance between previous records is greater than parameter’s value. If value is 0 it means no records by min distance will be saved.

Minimum value	Maximum value	Recommended value	Goes with (depends on) parameters	Value type
0	65535	-	Min Period (ID=1570) Min Angle (ID=1572) GPRS Week Time (ID=1575)	U32

8.5..27 Min Angle (ID=1592)

This parameter indicates angle in degrees in order to acquire new record. If angle difference between last recorded coordinate and current position is greater than defined value, new record is stored. This parameter is operational, when speed is higher than 10km/h. If value is 0 it means no records by min angle will be saved.

Minimum value	Maximum value	Recommended value	Goes with (depends on) parameters	Value type
0	180	-	Min Period (ID=1570) Min Angle (ID=1572) GPRS Week Time (ID=1575)	U16

8.5..28 Min Saved Records (ID=1593)

This parameter defines minimum number of records in one data packet that can be sent to server. It has higher priority than Data Send Period (ID=1594).

Minimum value	Maximum value	Recommended value	Goes with (depends on) parameters	Value type
1	255	1	Min Period (ID=1590) Min Distance (ID=1591) Min Angle (ID=1592) GPRS Week Time (ID=1595)	U8

8.5..29 Send Period (ID=1594)

This parameter indicates frequency (time interval in seconds) of sending data to server. In order to send data to server GPRS parameters must be enabled

Minimum value	Maximum value	Recommended value	Goes with (depends on) parameters	Value type
0	2592000	-	Min Saved Records (ID=1593) GPRS Week Time (ID=1595)	U32

8.5..30 GPRS Week Time (ID=1595)

Read chapter 8.5..4.

8.6 Features Parameters

- **Scenarios Enable (ID=1600)**

Device can operate in its scenario according to selected value: No Scenario selected (value 0); Green Driving selected (value 1), Overspeeding selected (value 2), Green Driving & Overspeeding selected (value 3).

Minimum value	Maximum value	Recommended value	Goes with (depends on) parameters	Value type
0	3	-		U8

- **Max Acceleration Force (ID=1602)**

It is max allowed acceleration force which can be reached while accelerating without triggering harsh acceleration event.

Minimum value	Maximum value	Recommended value	Goes with (depends on) parameters	Value type
0.25	0.85	0.25	Scenarios Enable (ID=1600)	Float

- **Max Braking Force (ID=1603)**

It is max allowed braking force which can be reached while braking without triggering harsh braking event.

Minimum value	Maximum value	Recommended value	Goes with (depends on) parameters	Value type
0.25	0.85	0.35	Scenarios Enable (ID=1600)	Float

- **Max Angular Velocity (ID=1604)**

It is max allowed cornering angle which can be reached while cornering without triggering harsh cornering event.

Minimum value	Maximum value	Recommended value	Goes with (depends on) parameters	Value type
0.1	1.0	-	Scenarios Enable (ID=1600)	U16

- **Max allowed Speed (ID=1605)**

It is max allowed speed which can be reached. If this value exceeded Over speeding event will occur.

Minimum value	Maximum value	Recommended value	Goes with (depends on) parameters	Value type
0	260	-	Scenarios Enable (ID=1600)	U16

- **Trip (ID=1280)**

This parameter enables ability to detect START and STOP of the trip.

Minimum value	Maximum value	Recommended value	Goes with (depends on) parameters	Value type
0	1	-		U8

- **Start Speed (ID=1281)**

This parameter represents speed, which is detected as minimum speed to indicate TRIP START and generate event.

Minimum value	Maximum value	Recommended value	Goes with (depends on) parameters	Value type

0	255	-	Trip (ID=1280)	U8
---	-----	---	-----------------------	----

- **Ignition Off Timeout (ID=1282)**

This parameter represents timeout to wait if ignition is off in order to detect TRIP STOP and generate event.

Minimum value	Maximum value	Recommended value	Goes with (depends on) parameters	Value type
0	65535	-	Trip (ID=1280)	U16

- **Trip Continuous distance counting (ID=1283)**

For this feature I/O#11 ODOMETER must be enabled. If I/O ODOMETER is enabled, and Continuous distance counting variable is set to Continuous (value 1), TRIP distance is going to be counted continuously (from TRIP start to TRIP stop) and shown as I/O ODOMETER value.

Minimum value	Maximum value	Recommended value	Goes with (depends on) parameters	Value type
0	1	-	Trip (ID=1280) I/O#11 – Odometer (ID = 1410-1415)	U8

- **Geofencing**

In this chapter it is explained how to get all parameters for the first Geofence zone (all ID numbers are for the 1st zone). And at the end of the chapter (part 8.6.10) is presented a table with the IDs of all the rest Geofence zones.

8.6..1 Frame border (ID=1020)

Geofence border thickness, measured in meters.

Minimum value	Maximum value	Recommended value	Goes with (depends on) parameters	Value type
0	1000000	1000	All Geofencing parameters	U32

8.6..2 Geofence Zone #1 Shape (ID=1030)

Geofence shape parameter can be: circle – value 0; rectangle – value 1.

Minimum value	Maximum value	Recommended value	Goes with (depends on) parameters	Value type
0	1	-	All Geofencing parameters	U8

8.6..3 Geofence Zone #1 Priority (ID=1031)

Parameter defines Geofence priority: 0 is low, 1 – high, 2 – panic;

Minimum value	Maximum value	Recommended value	Goes with (depends on) parameters	Value type

0	2	-	All Geofencing parameters	U8
---	---	---	---------------------------	----

8.6..4 Geofence Zone #1 Generate Event (ID=1032)

Generate event on:

- a) No event – value 0
- b) On entering zone – value 1;
- c) On exiting zone – value 2;
- d) On both – value 3;

Minimum value	Maximum value	Recommended value	Goes with (depends on) parameters	Value type
0	3	-	All Geofencing parameters	U8

8.6..5 Geofence Zone #1 Longitude (X1) (ID=1033)

Parameter has two meanings dependent on zone shape. If shape is a rectangle, then ID=1033 is left down corner X coordinate. If shape is a circle, then ID=1033 is center of that circle X coordinate.

Sample value: 25.30528

Minimum value	Maximum value	Recommended value	Goes with (depends on) parameters	Value type
-180	180	-	All Geofencing parameters	Float

8.6..6 Geofence Zone #1 Latitude (Y1) (ID=1034)

Parameter has two meanings dependent on zone shape. If shape is a rectangle, then ID=1034 is left down corner Y coordinate. If shape is a circle, then ID=1034 is center of that circle Y coordinate.

Minimum value	Maximum value	Recommended value	Goes with (depends on) parameters	Value type
-90	90	-	All Geofencing parameters	Float

8.6..7 Geofence Zone #1 Longitude (X2) (ID=1035)

Parameter has two meanings depending on zone shape. If shape is a rectangle, then ID=1035 is right upper corner X coordinate. If shape is a circle, then ID=1035 is radius of circle with center of ID=1033 and ID=1034.

For rectangle:

Minimum value	Maximum value	Recommended value	Goes with (depends on) parameters	Value type
-180	180	-	All Geofencing parameters	Float

For circle:

Minimum value	Maximum value	Recommended value	Goes with (depends on) parameters	Value type
0	1000000	1000	All Geofencing parameters	Float

8.6..8 Geofence Zone #1 Latitude (Y2) (ID=1036)

If shape is rectangular, then ID=1036 is right upper corner Y coordinate. If shape circle, ID=1036 is not used.

Minimum value	Maximum value	Recommended value	Goes with (depends on) parameters	Value type
-90	90	-	All Geofencing parameters	Float

Other 4 GeoFence zone's parameters have the same logic as shown in GeoFence Zone #1.

GeoFence Zone Number	Geofence Zone's parameters
1	1030-1036
2	1040-1046
3	1050-1056
4	1060-1066
5	1070-1076

- **AutoGeofencing**

8.6..9 Enable/Disable (ID=1101)

Enable – value 1; disable – value 0;

Minimum value	Maximum value	Recommended value	Goes with (depends on) parameters	Value type
0	1	1		U8

8.6..10 Activation Timeout (ID=1102)

Parameter represents AutoGeofencing activation timeout in seconds.

Minimum value	Maximum value	Recommended value	Goes with (depends on) parameters	Value type
0	65535	60	Enable/Disable (ID=1101)	U16

8.6..11 AutoGeofence event Priority (ID=1103)

Parameter defines AutoGeofence event priority: 0 is low, 1 – high;

Minimum value	Maximum value	Recommended value	Goes with (depends on) parameters	Value type
0	1	1	Enable/Disable (ID=1101) AutoGeofence event generating (ID=1104)	U8

8.6..12 AutoGeofence event generating (ID=1104)

Generate event: 0 – no event, 1 - on entering zone; 2 – on exiting zone; 3 – on both;

Minimum value	Maximum value	Recommended value	Goes with (depends on) parameters	Value type
0	3	2	Enable/Disable (ID=1101)	U8

			AutoGeofence event Priority (ID=1103)	
--	--	--	--	--

8.6..13 Radius (ID=1105)

Parameter represents radius of circle with center device coordinates after activating AutoGeofence feature.

Minimum value	Maximum value	Recommended value	Goes with (depends on) parameters	Value type
0	1000000	100	Enable/Disable (ID=1101)	U32

8.7 Accelerometer parameters

8.7..1 Acceleration range configuration (ID=1290)

Parameter represents range of movement detection in G force.

Minimum value	Maximum value	Recommended value	Goes with (depends on) parameters	Value type
2	16	2	Ignition Source (ID=1003)	U32

8.7..2 Acceleration threshold configuration (ID=1291)

Parameter represents threshold when movement is detected in mG.

Minimum value	Maximum value	Recommended value	Goes with (depends on) parameters	Value type
1	16 000	200	Ignition Source (ID=1003)	U32

8.7..3 Acceleration duration (ID=1292)

Parameter specifies how long acceleration must present on any axis for movement to be detected in milliseconds.

Minimum value	Maximum value	Recommended value	Goes with (depends on) parameters	Value type
0	600	0	Ignition Source (ID=1003)	U32

8.7..4 Movement filter start (ID=1293)

Parameter represents how long it takes to generate movement event in seconds.

Minimum value	Maximum value	Recommended value	Goes with (depends on) parameters	Value type
1	60	0	Ignition Source (ID=1003)	U32

8.7..5 Movement filer stop (ID=1294)

Parameter represents how long it takes to change movement I/O element state from 1 to 0 in seconds.

Minimum value	Maximum value	Recommended value	Goes with (depends on) parameters	Value type
1	300	60	Ignition Source (ID=1003)	U32

8.8 I/O parameters

I/O properties are additional data sources which are recorded along with usual GNSS data.

- **I/O#1 property parameter (ID=1300)**

Parameter defines I/O property value. Possible values: enabled (1), disabled (0).

Minimum value	Maximum value	Recommended value	Goes with (depends on) parameters	Value type
0	1	-	I/O#1 priority (ID=1301) I/O#1 High level (ID=1302) I/O#1 Low level (ID=1303) I/O#1 logic operand (ID=1304) I/O#1 averaging length (ID=1305)	S8

- **I/O#1 priority (ID=1301)**

Parameter defines I/O property type of priority: 0 is low, 1 – high, 2 – panic.

Minimum value	Maximum value	Recommended value	Goes with (depends on) parameters	Value type
0	2	0	I/O#1 property parameter (ID=1300) I/O#1 High level (ID=1302) I/O#1 Low level (ID=1303) I/O#1 logic operand (ID=1304) I/O#1 averaging length (ID=1305)	S8

- **I/O#1 High level (ID=1302)**

Parameter defines high value of triggered I/O property. This parameter is used to set thresholds for I/O properties to generate events.

Minimum value	Maximum value	Recommended value	Goes with (depends on) parameters	Value type
-2147483648	2147483647	1	I/O#1 property parameter (ID=1300) I/O#1 priority (ID=1301) I/O#1 Low level (ID=1303) I/O#1 logic operand (ID=1304) I/O#1 averaging length (ID=1305)	S32

- **I/O#1 Low level (ID=1303)**

Parameter defines low value of triggered I/O property. This parameter is used to set thresholds for I/O properties to generate events.

Minimum value	Maximum value	Recommended value	Goes with (depends on) parameters	Value type
-2147483648	2147483647	0	I/O#1 property parameter (ID=1300) I/O#1 priority (ID=1301) I/O#1 High level (ID=1302) I/O#1 logic operand (ID=1304) I/O#1 averaging length (ID=1305)	S32

- **I/O#1 logic operand (ID=1304)**

Parameter defines when event is sent: 0 – on range exit, 1 – on range entrance, 2 – both, 3 – monitoring, 4 – hysteresis.

Minimal value	Maximum value	Recommended value	Goes with (depends on) parameters	Value type
0	4	3	I/O#1 property parameter (ID=1300) I/O#1 priority (ID=1301) I/O#1 High level (ID=1302) I/O#1 Low level (ID=1303) I/O#1 averaging length (ID=1305)	S8

- **I/O#1 averaging length (ID=1305)**

Parameter defines I/O property sample length to average. If no averaging needed default value is 1.

Minimum value	Maximum value	Recommended value	Goes with (depends on) parameters	Value type
0	2592000	1	I/O#1 property parameter (ID=1300) I/O#1 priority (ID=1301) I/O#1 High level (ID=1302) I/O#1 Low level (ID=1303) I/O#1 logic operand (ID=1304)	S32

Other I/O property elements can be configured in same logic. All I/O element parameters are listed in the next table.

I/O Element Number	I/O element parameters
I/O#0 – Digital input 1	1300 – 1305
I/O#1 – PDOP	1310 – 1315
I/O#2 – HDOP	1320 – 1325
I/O#3 – Power voltage	1330 – 1335
I/O#4 – Movement	1340 – 1345
I/O#5 – Odometer	1350 – 1355
I/O#6 – Actual operator Code	1360 – 1365
I/O#7 – Speedometer	1370 – 1375
I/O#8 – Operating Mode	1380 – 1385
I/O#9 – GSM Signal	1390 – 1395
I/O#10 – Deep Sleep	1400 – 1405
I/O#11 – Cell ID	1410 – 1415
I/O#12 – Area Code	1420 – 1425
I/O#13 – Battery Voltage	1430 – 1435
I/O#14 – Battery Current	1440 – 1445

8.9 SMS event configuration

- **I/O#1 element SMS event configuration (ID=100)**

Command sets SMS warning on I/O#1 element.

SMS Format: setparam X,Y,W,Z

X – ID

Y – Enable/Disable (0/1)

W – Telephone number INDEX (See **8.4.13 SMS Event Predefined Numbers** paragraph, ID 150 – INDEX 1; ID151 – INDEX 2, ...)

Z – SMS Text

Example: “setparam 100 1,5,Digital Input 1 Event!”

Other I/O element SMS events can be configured in same logic. All I/O element SMS event IDs are listed in the next table.

Element name (default SMS Event Text)	ID
Digital Input 1	100
PDOP	101
HDOP	102
Power voltage	103
Movement	104
Odometer	105
Actual operator Code	106
Speedometer	107
Operating Mode	108

GSM Signal	109
Deep Sleep	110
Cell ID	111
Area Code	112
Battery Voltage	113
Battery Current	114
Green Driving	125
OverSpeeding	126
Trip	127
Geo Zone 1	128
Geo Zone 2	129
Geo Zone 3	130
Geo Zone 4	131
Geo Zone 5	132
Auto Geofence	133

9 Module installation

9.1 Installing FM1010 module:

- 1) Locate OBD-II connector in your car (see car owner's manual for the location of the connector)
- 2) Plug in FM1010 device in OBD-II connector.
- 3) If status and navigate led lights turn on, device is ready to use.

9.2 Installation recommendations:

- 1) SIM card should be inserted in the module while the connector is plugged off (while module has no power).
- 2) Please ascertain that the module is firmly embedded in the OBD-II connector.

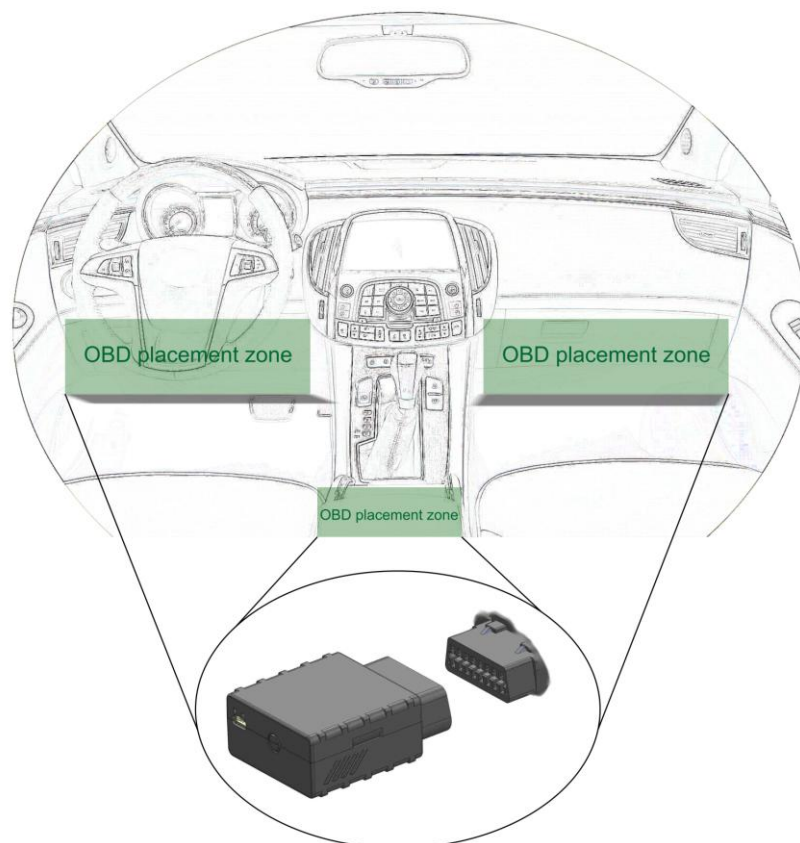

Figure 40 Correct placement of FM1010



Note: I/O element's "Movement" Averaging constant is interpreted as Start Move Timeout in seconds (from 1 to 59).
 Start Move Timeout – is a time interval required for accelerometer to be in the moving state, to consider vehicle as moving.



Warning! Do not use FM1010 device if it distracts driver or causes inconvenience due to OBD II placement. Device must not interfere with driver!

10 CHANGE LOG

Nr.	Date	Version	Comments
1	2014.06.27	0.1	First Draft created
2	2014.07.01	1.0	Removed all OBD elements, updated pictures
3	2014.08.04	1.1	Added information about home operator searching mode.